

The new **BHT** boring system is characterized by the new **HT** coupling suitable for medium-heavy machining, characterized by strong torsional components with maximum concentricity.

BHT bars cover a working range from \varnothing 250 to \varnothing 750 mm, both in roughing and finishing.

The wide range of accessories includes adjustable ISO-CA roughing cartridges and a standard TRM 63 finishing micrometric head, suitable for boring, chamfering and back-facing operations.

The system in FINISHING configuration can be balanced by using counterweights.

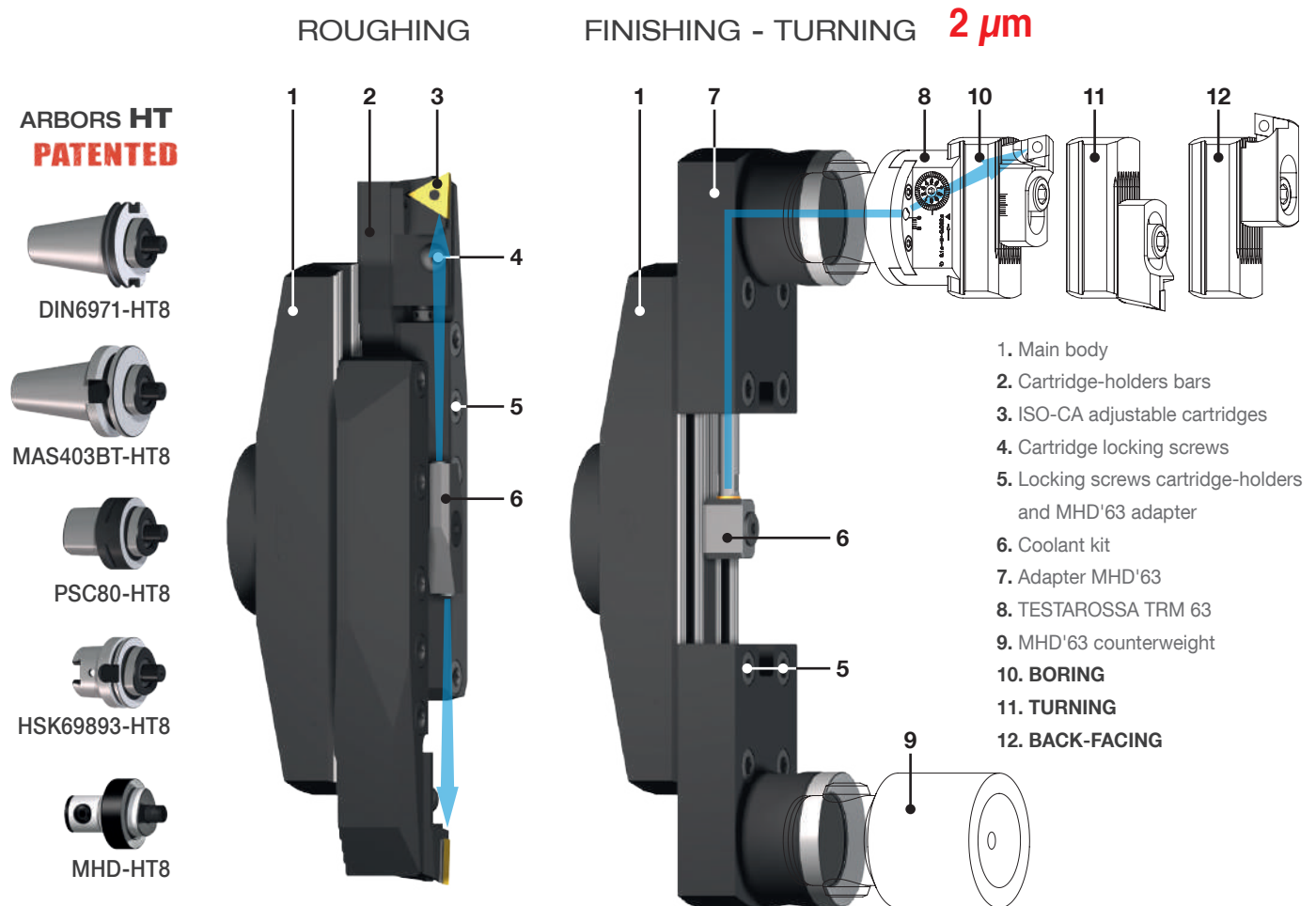

12. BACKWARD

For **ROUGHING** operations
use TS 63/63+SSQC 63 see page 26

For **FINISHING** operations
use TRM 63+PS..+SFQC 50 see page 26

REF.	CODE	\varnothing	A	kg
BHT 250	435508882460	250 ~ 500	246	4.2
BHT 500	435508882960	500 ~ 750	496	7.8

REF.	CODE	kg
DIN 69871-AD50 - HT8.36.5	41HT08025000	3.4
MAS403BT-AD50 - HT8.38.5	41HT08035000	3.7
PSC 80 - HT8.30	41HT08018000	2
HSK 100 - HT8.76.5	41HT08041000	4
MHD' 80 - HT8	655108000080	2

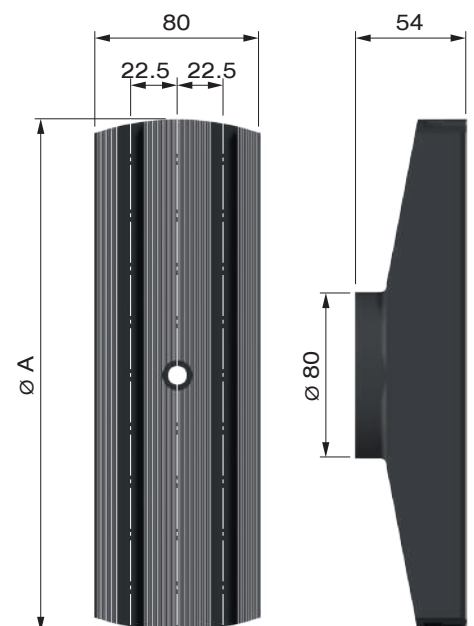

BHT Ø 250 ~ 750

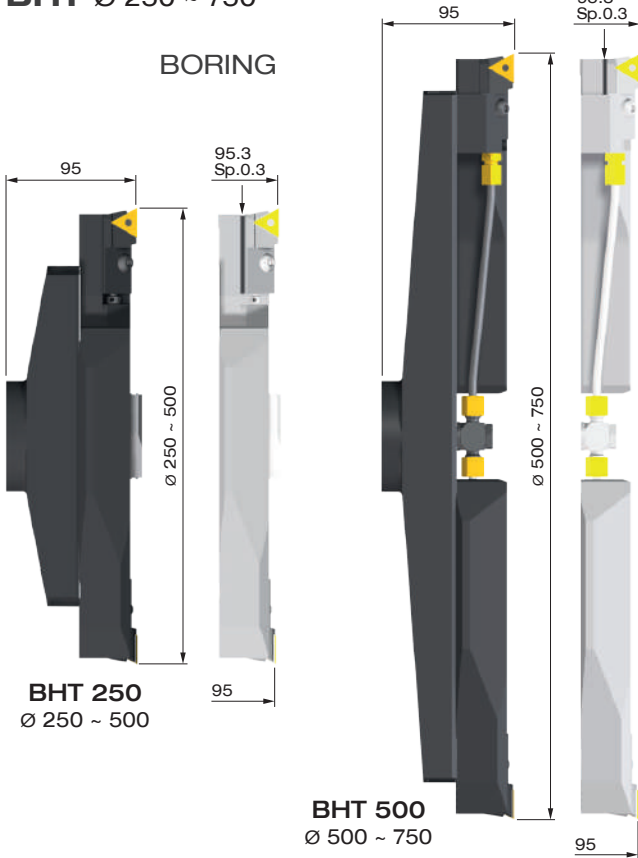

FINISHING - TURNING 2 µm

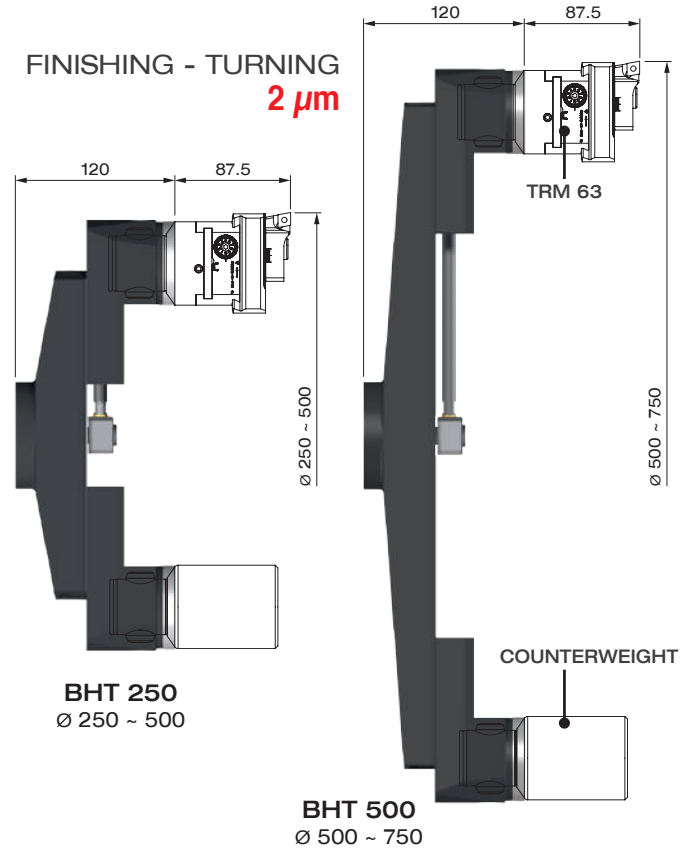

ISO-CA CARTRIDGE HOLDERS

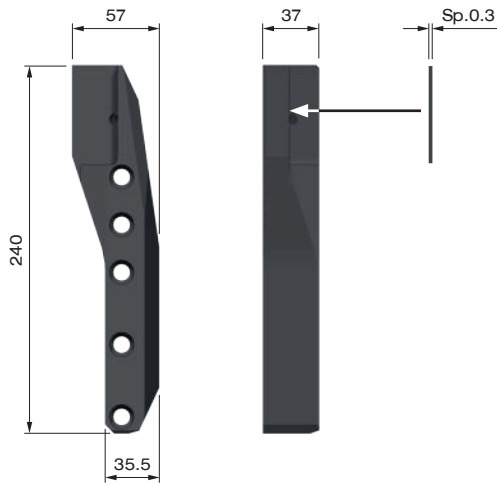

REF.	CODE	kg
ISO-CA CARTRIDGE HOLDERS BHT 250-500	382090024000	2.5

ADAPTER MHD'63

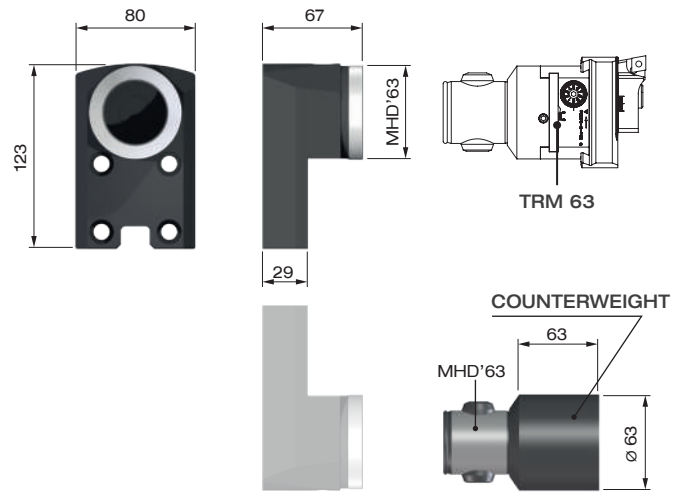

REF.	CODE	kg
ADAPTER MHD'63 BHT 250-500	382090006301	2.5
COUNTERWEIGHT MHD'63 BHT 250-500	392011006300	2.4

COOLANT KIT

KIT RFG BHT 250 SG	KIT RFG BHT 500 SG	KIT RFG BHT 250 FN	KIT RFG BHT 500 FN
CODE 382090025000	CODE 382090050003	CODE 382090025001	CODE 382090050004

CARTRIDGES 20CA ISO 5611

PTGNL20CA-22	PCGNL20CA-16	SCGCL20CA-12	PSRNL20CA-15
CODE 483010201001	CODE 483010201002	CODE 483010201003	CODE 483010201004
TNM2204	CNM1606	CCM1204	SNM1506