































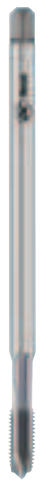

























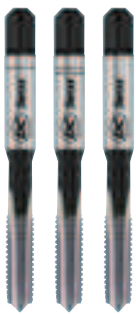
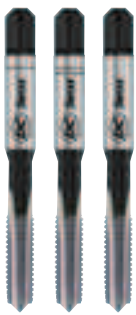
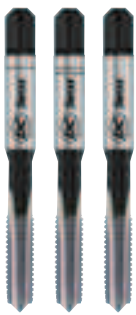















































		N						
Характеристики Cechy charakterystyczne				 V	 TiN TiCN	 		 V
Типы отверстий Typ otworu								
		N310-3	N320-3 N320-4	N320V-3 N320V-4	N320TN-3/4 N320TC-3/4	N321-3 N321-4	N330-3 N330-4	N330V-3 N330V-4
Длинный по DIN DIN długi	DIN 371	22	22/24	24	24	30	30	30
Особо длинный Extra-długi	DC							
Короткий по ISO ISO krótki	ISO 529							
Короткий по DIN DIN krótki	DIN 352							
Длинный по DIN DIN długi	~DIN 2174							
Класс точности Tolerancja	ISO 2 6H	22	22/24	24	24	30	30	30
Класс точности Nadwymiar	ISO 3 6G		28	28				
Класс точности Nadwymiar	7G		28					
Класс точности Nadwymiar	+ 0.10 mm + 0.20 mm		28					
Повышенный класс точности Tolerancja dokładna	ISO 1 4H		26					
Левая резьба LH Gwint lewy	ISO 2 6H	22	26	26				
		N410-3	N420-4	N420V-4	N420TN-4 N420TC-4	N421-4	N430-4	N430V-4
Длинный по DIN DIN długi	DIN 371	23	25	25	25	31	31	31
Особо длинный Extra-długi	DC							
Короткий по ISO ISO krótki	ISO 529							
Короткий по DIN DIN krótki	DIN 352							
Длинный по DIN DIN długi	~DIN 2174							
Класс точности Tolerancja	ISO 2 6H	23	25	25	25	31	31	31
Класс точности Nadwymiar	ISO 3 6G		29	29				
Класс точности Nadwymiar	7G		29					
Класс точности Nadwymiar	+ 0.10 mm + 0.20 mm		29/31					
Повышенный класс точности Tolerancja dokładna	ISO 1 4H		27					
Левая резьба LH Gwint lewy	ISO 2 6H	23	27	27				

N								
 R15	 R40	 R40	 R40	 R40	 R40	 R40	 V	 V
 V		 V	 TiN TiCN	 E 1.5xP		 V		 V
								
								
<b>N350-3 N350V-3</b>	<b>N360-3</b>	<b>N360V-3</b>	<b>N360TN-3 N360TC-3</b>	<b>N360-5 N360V-5</b>	<b>N361-3</b>	<b>N362V-3</b>	<b>N520-4</b>	<b>N520V-4</b>
32	34	34	34	40	40	40	42	42
32	34	34	34	40	40	40	42	42
	36	36						
	38	38						
	38							
	36	36						
<b>N450-3 N450V-3</b>	<b>N460-3</b>	<b>N460V-3</b>	<b>N460TN-3 N460TC-3</b>	<b>N460-5 N460V-5</b>	<b>N461-3</b>	<b>N462V-3</b>	<b>N620-4</b>	<b>N620V-4</b>
33	35	35	35	41	41	41	43	43
33	35	35	35	41	41	41	43	43
	37	37						
	39	39						
	39							
	39							
	37	37						

























		N								
Характеристики Cechy charakterystyczne		 TiN	 R40	 R40	 V	 R40	 TiN		 R40	
										
Типы отверстий Typ otworu										
		<b>N520TN-4</b>	<b>N560-3</b>	<b>N560V-3</b>	<b>N560TN-3</b>	<b>N1120-4</b>	<b>N1160-3</b>	<b>N1110-1-2-3-S</b>	<b>N1110-1-2-3-S</b>	<b>N1110-1-2-3-S</b>
Длинный по DIN DIN długi	DIN 371									
Особо длинный Extra-długi	DC	42	44	44	44					
Короткий по ISO ISO krótki	ISO 529					78	78	76		
Короткий по DIN DIN krótki	DIN 352									
Длинный по DIN DIN długi	~DIN 2174									
Класс точности Tolerancja	ISO 2 6H	42	44	44	44	78	78	76		
Класс точности Nadwymiar	ISO 3 6G									
Класс точности Nadwymiar	7G									
Класс точности Nadwymiar	+ 0.10 mm + 0.20 mm									
Повышенный класс точности Tolerancja dokładna	ISO 1 4H									
Левая резьба LH Gwint lewy	ISO 2 6H									
		<b>N620TN-4</b>	<b>N660-3</b>	<b>N660V-3</b>	<b>N660TN-3</b>	<b>N1220-4</b>	<b>N1260-3</b>	<b>N1210-1-2-3-S</b>	<b>N1210-1-2-3-S</b>	<b>N1210-1-2-3-S</b>
Длинный по DIN DIN długi	DIN 371									
Особо длинный Extra-długi	DC	43	45	45	45					
Короткий по ISO ISO krótki	ISO 529					78	78	77		
Короткий по DIN DIN krótki	DIN 352									
Длинный по DIN DIN długi	~DIN 2174									
Класс точности Tolerancja	ISO 2 6H	43	45	45	45	78	78	77		
Класс точности Nadwymiar	ISO 3 6G									
Класс точности Nadwymiar	7G									
Класс точности Nadwymiar	+ 0.10 mm + 0.20 mm									
Повышенный класс точности Tolerancja dokładna	ISO 1 4H									
Левая резьба LH Gwint lewy	ISO 2 6H									

	W				Z			
		 <b>DL</b>		 <b>DL</b>		 <b>VS</b>		 <b>VS</b>
		 <b>NEW</b>		 <b>NEW</b>				
								
	<b>W320-3</b> W320-4	<b>W320DL-3</b> W320DL-4	<b>W360-3</b>	<b>W360DL-3</b>	<b>Z320V-3</b> Z320V-4	<b>Z320VS-4</b>	<b>Z360V-3</b> Z362V-3	<b>Z360VS-3</b> Z362VS-3
	46	46	47	47	48	48	49	50
	46	46	47	47	48	48	49	50
	<b>W420-4</b>	<b>W420DL-4</b>	<b>W460-3</b>	<b>W460DL-3</b>	<b>Z420V-4</b>	<b>Z420VS-4</b>	<b>Z462V-3</b>	<b>Z462VS-3</b>
	46	46	47	47	48	48	49	51
	46	46	47	47	48	48	49	51

		<b>Z</b>	<b>H</b>	<b>S</b>	<b>SA</b>			
<b>Характеристики</b> <b>Cechy charakterystyczne</b>		 <b>VS</b>	 <b>VS</b>	 <b>TiCN</b>	 <b>VS</b>	 <b>VS</b>		
								
<b>Типы отверстий</b> <b>Typ otworu</b>								
		<b>Z370VS-3</b>	<b>Z373VS-3</b>	<b>H320-4</b> <b>H320TC-4</b>	<b>H350-3</b> <b>H350TC-3</b>	<b>S320VS-4</b>	<b>S360VS-3</b>	<b>SA320-4</b>
<b>Длинный по DIN</b> <b>DIN długi</b>	<b>DIN 371</b>	50	50	52	54	56	57	58
<b>Особо длинный</b> <b>Extra-długi</b>	<b>DC</b>							
<b>Короткий по ISO</b> <b>ISO krótki</b>	<b>ISO 529</b>							
<b>Короткий по DIN</b> <b>DIN krótki</b>	<b>DIN 352</b>							
<b>Длинный по DIN</b> <b>DIN długi</b>	<b>~DIN 2174</b>							
<b>Класс точности</b> <b>Tolerancja</b>	<b>ISO 2 6H</b>	50	50	52	54	56	57	58
<b>Класс точности</b> <b>Nadwymiar</b>	<b>ISO 3 6G</b>				54			
<b>Класс точности</b> <b>Nadwymiar</b>	<b>7G</b>							
<b>Класс точности</b> <b>Nadwymiar</b>	<b>+ 0.10 mm</b> <b>+ 0.20 mm</b>							
<b>Повышенный класс точности</b> <b>Tolerancja dokładna</b>	<b>ISO 1 4H</b>	50				56		58
<b>Левая резьба</b> <b>LH Gwint lewy</b>	<b>ISO 2 6H</b>							
		<b>Z470VS-3</b>	<b>Z473VS-3</b>	<b>H420-4</b> <b>H420TC-4</b>	<b>H450-3</b> <b>H450TC-3</b>	<b>S420VS-4</b>	<b>S460VS-3</b>	<b>SA420-4</b>
<b>Длинный по DIN</b> <b>DIN długi</b>	<b>DIN 371</b>	51	51	53	55	56	57	59
<b>Особо длинный</b> <b>Extra-długi</b>	<b>DC</b>							
<b>Короткий по ISO</b> <b>ISO krótki</b>	<b>ISO 529</b>							
<b>Короткий по DIN</b> <b>DIN krótki</b>	<b>DIN 352</b>							
<b>Длинный по DIN</b> <b>DIN długi</b>	<b>~DIN 2174</b>							
<b>Класс точности</b> <b>Tolerancja</b>	<b>ISO 2 6H</b>	51	51	53	55	56	57	59
<b>Класс точности</b> <b>Nadwymiar</b>	<b>ISO 3 6G</b>				55			
<b>Класс точности</b> <b>Nadwymiar</b>	<b>7G</b>							
<b>Класс точности</b> <b>Nadwymiar</b>	<b>+ 0.10 mm</b> <b>+ 0.20 mm</b>							
<b>Повышенный класс точности</b> <b>Tolerancja dokładna</b>	<b>ISO 1 4H</b>							59
<b>Левая резьба</b> <b>LH Gwint lewy</b>	<b>ISO 2 6H</b>							





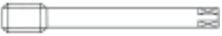







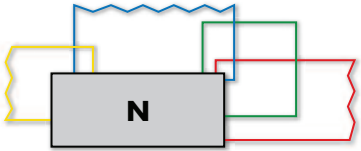

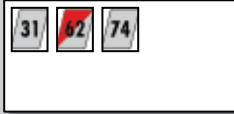







SA		TL		GG			K		
					NV				
<b>SA350-3</b>	<b>SA390-3</b>	<b>TL320VS-4</b>	<b>TL351VS-3</b>	<b>GG350NV-3</b> <b>GG550NV-3</b>	<b>GG350TC-3</b>	<b>GG353TC-3</b>	<b>K313TC-3</b>		
58	57	58	58	60 60	60	60	66		
58	57	58	58	60	60	60	66		
58	57	58	58						
<b>SA450-3</b>		<b>TL420VS-4</b>	<b>TL451VS-3</b>	<b>GG450NV-3</b> <b>GG650NV-3</b>	<b>GG450TC-3</b>	<b>GG453TC-3</b>	<b>K413TC-3</b> <b>K613TC-3</b>	<b>K613VS-3</b>	
59		59	59	61 61	61	61	66 67	67	
59		59	59	61	61	61	66/67	67	
59		59	59						

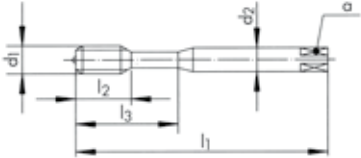







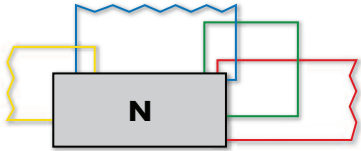

		RTS							
Характеристики Cechy charakterystyczne									
	VS	VS	VS	VS	E 1.5 x P VS				
									
Типы отверстий Typ otworu									
		RTS320VS-4	RTS323VS-4	RTS360VS-3 RTS362VS-3	RTS365VS-3	RTS362VS-5 RTS365VS-5	RTS523VS-4	RTS565VS-3	
Длинный по DIN DIN długi	DIN 371	62	62	63	63	64			
Особо длинный Extra-długi	DC						65	65	
Короткий по ISO ISO krótki	ISO 529								
Короткий по DIN DIN krótki	DIN 352								
Длинный по DIN DIN długi	~DIN 2174								
Класс точности Tolerancja	ISO 2 6H	62	62	63	63	64	65	65	
Класс точности Nadwymiar	ISO 3 6G			64					
Класс точности Nadwymiar	7G								
Класс точности Nadwymiar	+ 0.10 mm + 0.20 mm								
Повышенный класс точности Tolerancja dokładna	ISO 1 4H								
Левая резьба LH Gwint lewy	ISO 2 6H								
		RTS420VS-4	RTS423VS-4	RTS462VS-3	RTS465VS-3		RTS623VS-4	RTS665VS-3	
Длинный по DIN DIN długi	DIN 371	62	62	63	63				
Особо длинный Extra-długi	DC						65	65	
Короткий по ISO ISO krótki	ISO 529								
Короткий по DIN DIN krótki	DIN 352								
Длинный по DIN DIN długi	~DIN 2174								
Класс точности Tolerancja	ISO 2 6H	62	62	63	63		65	65	
Класс точности Nadwymiar	ISO 3 6G								
Класс точности Nadwymiar	7G								
Класс точности Nadwymiar	+ 0.10 mm + 0.20 mm								
Повышенный класс точности Tolerancja dokładna	ISO 1 4H								
Левая резьба LH Gwint lewy	ISO 2 6H								

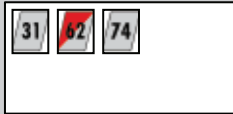

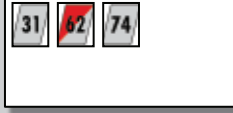
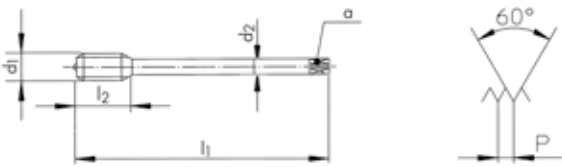







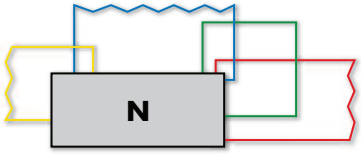





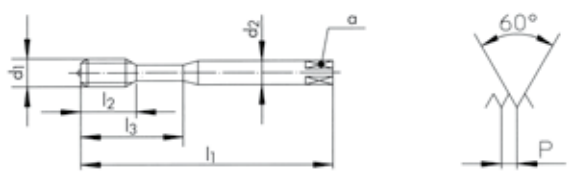







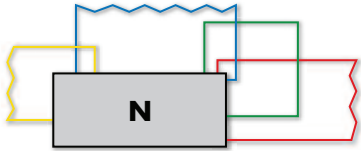



FS				FPS				FAS						
<b>NEW</b>	<b>NEW</b>	<b>NEW</b>	<b>NEW</b>	<b>NEW</b>	<b>NEW</b>	<b>NEW</b>	<b>NEW</b>	<b>NEW</b>	<b>NEW</b>	<b>NEW</b>	<b>NEW</b>	<b>NEW</b>	<b>NEW</b>	<b>NEW</b>
<b>FS380VS-5</b> <b>FS380VS-3</b>	<b>FS380DL-5</b> <b>FS380DL-3</b>	<b>FPS380CN-3</b> <b>FPS381CN-3</b>	<b>FPS380VS-3</b> <b>FPS381VS-3</b>	<b>FPS384VS-3</b>	<b>FPS581VS-3</b> <b>FPS584VS-3</b>	<b>FAS380VS-3</b> <b>FAS381VS-3</b>	<b>FAS384VS-3</b>	<b>FAS581VS-3</b> <b>FAS584VS-3</b>	<b>FAS581VS-3</b> <b>FAS584VS-3</b>	<b>FAS380VS-3</b> <b>FAS381VS-3</b>	<b>FAS384VS-3</b>	<b>FAS581VS-3</b> <b>FAS584VS-3</b>	<b>FAS581VS-3</b> <b>FAS584VS-3</b>	<b>FAS581VS-3</b> <b>FAS584VS-3</b>
					71/72				75					
68	69	70	70	72		73	74			73	74			
68	69	70	70	72	71/72	73	74			73	74			75
68	69		70											
			<b>FPS481VS-3</b>	<b>FPS484VS-3</b>	<b>FPS681VS-3</b> <b>FPS684VS-3</b>	<b>FAS481VS-3</b>	<b>FAS484VS-3</b>	<b>FAS681VS-3</b> <b>FAS684VS-3</b>	<b>FAS681VS-3</b> <b>FAS684VS-3</b>	<b>FAS481VS-3</b>	<b>FAS484VS-3</b>	<b>FAS681VS-3</b> <b>FAS684VS-3</b>	<b>FAS681VS-3</b> <b>FAS684VS-3</b>	<b>FAS681VS-3</b> <b>FAS684VS-3</b>
					71/72				75					
			71	72		73	74			73	74			
			71	72	71/72	73	74			73	74			75



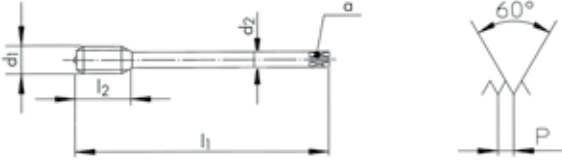







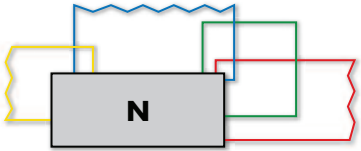

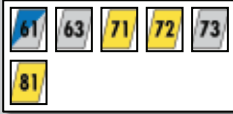







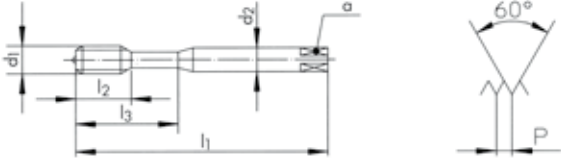

									N310-3	N310-3 LH	N320-3	
												
N310-3												
N310-3 LH	 LH											
N320-3												
 												
Ø d <sub>1</sub> M	P mm	l <sub>1</sub> mm	l <sub>2</sub> mm	l <sub>3</sub> mm	d <sub>2</sub> mm	a mm			ID	ID	ID	
1	0.25	40	5.5		2.5	2.1	3	0.75	150167			
1.1	0.25	40	5.5		2.5	2.1	3	0.85	174745			
1.2	0.25	40	5.5		2.5	2.1	3	0.95	150168			
1.4	0.30	40	7.0		2.5	2.1	3	1.10	150169			
1.5	0.30	40	7.0		2.5	2.1	3	1.20	174752			
1.6	0.35	40	8.0		2.5	2.1	3	1.25	174753			
1.7	0.35	40	8.0		2.5	2.1	3	1.35	174754			
1.8	0.35	40	8.0		2.5	2.1	3	1.45	174755			
2	0.40	45	8.0		2.8	2.1	3	1.60	101439	111460		
2.2	0.45	45	9.0		2.8	2.1	3	1.75	174756			
2.3	0.40	45	9.0		2.8	2.1	3	1.90	174757			
2.5	0.45	50	10.0		2.8	2.1	*3	2.05	101440	111461	* 101461	
2.6	0.45	50	10.0		2.8	2.1	3	2.15	101441			
3	0.50	56	12.0	18	3.5	2.7	*3	2.50	101442	111462	* 101462	
3.5	0.60	56	13.0	20	4.0	3.0	*3	2.90	101443		* 101463	
4	0.70	63	14.0	21	4.5	3.4	*3	3.30	101444	111464	* 101464	
5	0.80	70	15.0	25	6.0	4.9	*3	4.20	101445	111465	* 101465	
6	1.00	80	17.0	30	6.0	4.9	*3	5.00	101446	111466	* 101466	
8	1.25	90	20.0	35	8.0	6.2	3	6.80	101447			
10	1.50	100	22.0	39	10.0	8.0	3	8.50	101438			
* N320-3 =  2									≤ M1.5 			

								N410-3	N410-3 LH		
											
N410-3											
N410-3 LH	 LH										
											
											
$\emptyset d_1$ M	P mm	$l_1$ mm	$l_2$ mm	$d_2$ mm	$\alpha$ mm			ID	ID		
3	0.50	56	12.0	2.2	1.8	3	2.50	101897			
4	0.70	63	14.0	2.8	2.1	3	3.30	101924			
5	0.80	70	15.0	3.5	2.7	3	4.20	101942			
6	1.00	80	17.0	4.5	3.4	3	5.00	101953			
7	1.00	80	17.0	5.5	4.3	3	6.00	142645	111491		
8	1.25	90	20.0	6.0	4.9	3	6.80	101958	111492		
10	1.50	100	22.0	7.0	5.5	3	8.50	101866	111478		
12	1.75	110	24.0	9.0	7.0	3	10.20	101870	111479		
14	2.00	110	28.0	11.0	9.0	3	12.00	101874	111480		
16	2.00	110	30.0	12.0	9.0	3	14.00	101880	111481		
18	2.50	125	33.0	14.0	11.0	3	15.50	101883	111482		
20	2.50	140	36.0	16.0	12.0	3	17.50	101885	125530		
22	2.50	140	36.0	18.0	14.5	3	19.50	101888			
24	3.00	160	39.0	18.0	14.5	4	21.00	101891	111485		
27	3.00	160	42.0	20.0	16.0	4	24.00	101895	111486		
30	3.50	180	45.0	22.0	18.0	4	26.50	101901	111487		
33	3.50	180	48.0	25.0	20.0	4	29.50	101907			
36	4.00	200	51.0	28.0	22.0	4	32.00	101915	111488		
39	4.00	200	55.0	32.0	24.0	4	35.00	101922			
42	4.50	200	55.0	32.0	24.0	4	37.50	101932			
48	5.00	250	63.0	36.0	29.0	4	43.00	111489			
56	5.50	280	71.0	45.0	35.0	5	50.50	111447			

									N320-4	N320V-4	N320TN-4	N320TC-4	
													
N320-4													
N320V-4		<b>V</b>											
N320TN-4		<b>TiN</b>											
N320TC-4		<b>TiCN</b>											
													
													
Ø d <sub>1</sub> M	P mm	l <sub>1</sub> mm	l <sub>2</sub> mm	l <sub>3</sub> mm	d <sub>2</sub> mm	a mm			ID	ID	ID	ID	
*1	0.25	40	5.5		2.5	2.1	2	0.75	111467				
*1.1	0.25	40	5.5		2.5	2.1	2	0.85	111468				
*1.2	0.25	40	5.5		2.5	2.1	2	0.95	111469				
*1.4	0.30	40	7.0		2.5	2.1	2	1.10	111470				
*1.5	0.30	40	7.0		2.5	2.1	2	1.20	111471				
*1.6	0.35	40	8.0		2.5	2.1	2	1.25	101454				
*1.7	0.35	40	8.0		2.5	2.1	2	1.35	101455				
*1.8	0.35	40	8.0		2.5	2.1	2	1.45	101456				
*2	0.40	45	8.0		2.8	2.1	2	1.60	101458	101536	101528	152900	
*2.2	0.45	45	9.0		2.8	2.1	2	1.75	101459				
*2.3	0.40	45	9.0		2.8	2.1	2	1.90	101460				
2.5	0.45	50	10.0		2.8	2.1	3	2.05	101483	101545	101530	101522	
2.6	0.45	50	10.0		2.8	2.1	3	2.15	101484				
3	0.50	56	12.0	18	3.5	2.7	3	2.50	101485	101546	101531	101523	
3.5	0.60	56	13.0	20	4.0	3.0	3	2.90	101491	101547			
4	0.70	63	14.0	21	4.5	3.4	3	3.30	101495	101548	101532	101524	
5	0.80	70	15.0	25	6.0	4.9	3	4.20	101499	101549	101533	101525	
6	1.00	80	17.0	30	6.0	4.9	3	5.00	101503	101550	101534	101526	
8	1.25	90	20.0	35	8.0	6.2	3	6.80	101506	101551	101535	101527	
10	1.50	100	22.0	39	10.0	8.0	3	8.50	101481	101544	101529	101521	
<p>* N320-3 / N320V-3 N320TN-3 / N320TC-3</p> 									<p>≤ M1.5</p> 				

								N420-4	N420V-4	N420TN-4	N420TC-4
											
N420-4											
						61 63 71 72 73 81					
N420V-4		V									
						11 12 13 14 21 32					
N420TN-4		TiN									
						11 12 13 14 21 31 32 73 74					
N420TC-4		TiCN									
						11 12 13 14 21 31 32 73 74 82 83					
											
								ISO 2 6H	ISO 2 6H	ISO 2 6H	ISO 2 6H
Ø d <sub>1</sub> M	P mm	l <sub>1</sub> mm	l <sub>2</sub> mm	d <sub>2</sub> mm	α mm			ID	ID	ID	ID
3	0.50	56	12.0	2.2	1.8	3	2.50	102119	143418		
4	0.70	63	14.0	2.8	2.1	3	3.30	102146	102279		
5	0.80	70	15.0	3.5	2.7	3	4.20	102171	102280	146297	
6	1.00	80	17.0	4.5	3.4	3	5.00	102182	102282	147439	
7	1.00	80	17.0	5.5	4.3	3	6.00	102189	144713		
8	1.25	90	20.0	6.0	4.9	3	6.80	102195	102285	102251	102233
9	1.25	90	20.0	7.0	5.5	3	7.80	102202			
10	1.50	100	22.0	7.0	5.5	3	8.50	102061	102263	102240	102228
11	1.50	100	19.0	8.0	6.2	3	9.50	162770			
12	1.75	110	24.0	9.0	7.0	3	10.20	102072	102265	102243	102229
14	2.00	110	28.0	11.0	9.0	3	12.00	102081	102267	102245	
16	2.00	110	30.0	12.0	9.0	3	14.00	102090	102269	102247	102231
18	2.50	125	33.0	14.0	11.0	3	15.50	102097	102271		
20	2.50	140	36.0	16.0	12.0	3	17.50	102101	102273	102248	102232
22	2.50	140	36.0	18.0	14.5	3	19.50	102106	102275		
24	3.00	160	39.0	18.0	14.5	4	21.00	102110	102278	144220	163736
27	3.00	160	42.0	20.0	16.0	4	24.00	102117	143856		
30	3.50	180	45.0	22.0	18.0	4	26.50	102124	105124		
33	3.50	180	48.0	25.0	20.0	4	29.50	102130	146968		
36	4.00	200	51.0	28.0	22.0	4	32.00	102137	143430		
39	4.00	200	55.0	32.0	24.0	4	35.00	102144	158724		
42	4.50	200	55.0	32.0	24.0	4	37.50	102158	143107		
45	4.50	220	59.0	36.0	29.0	4	40.50	* 110225			
48	5.00	250	63.0	36.0	29.0	4	43.00	110226	157517		
56	5.50	280	71.0	45.0	35.0	5	50.50	110229	158178		

										N320-4	N320-4 LH	N320V-4 LH
										N320-4		
N320-4 LH	 <b>LH</b>											
N320V-4 LH	 <b>V</b> <b>LH</b>											
												
												
Ø d <sub>1</sub> M	P mm	l <sub>1</sub> mm	l <sub>2</sub> mm	l <sub>3</sub> mm	d <sub>2</sub> mm	a mm			ID	ID	ID	
*2	0.40	45	8.0		2.8	2.1	2	1.60	162503	111472	162771	
2.5	0.45	50	10.0		2.8	2.1	3	2.05	159345			
3	0.50	56	12.0	18	3.5	2.7	3	2.50	101487	111473	162772	
4	0.70	63	14.0	21	4.5	3.4	3	3.30	101493	111474	162773	
5	0.80	70	15.0	25	6.0	4.9	3	4.20	101497	111475	162774	
6	1.00	80	17.0	30	6.0	4.9	3	5.00	101501	111476	162775	
8	1.25	90	20.0	35	8.0	6.2	3	6.80	* 146482			
10	1.50	100	22.0	39	10.0	8.0	3	8.50	* 146484			

\* N320-3



<sup>Δ</sup> ISO 1 4H =  6.70

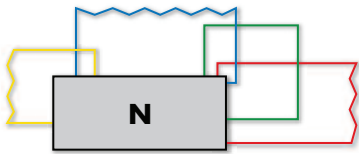

**N420-4**

**N420-4 LH** **LH**

**N420V-4 LH** **V** **LH**

N420-4

N420-4 LH

N420V-4 LH

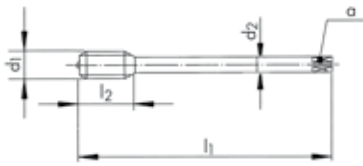

Ø d <sub>1</sub> M	P mm	l <sub>1</sub> mm	l <sub>2</sub> mm	d <sub>2</sub> mm	α mm		
8	1.25	90	20.0	6.0	4.9	3	Δ 6.80
10	1.50	100	22.0	7.0	5.5	3	8.50
12	1.75	110	24.0	9.0	7.0	3	10.20
14	2.00	110	28.0	11.0	9.0	3	12.00
16	2.00	110	30.0	12.0	9.0	3	14.00
20	2.50	140	36.0	16.0	12.0	3	17.50
24	3.00	160	39.0	18.0	14.5	4	21.00
30	3.50	180	45.0	22.0	18.0	4	26.50

ID

ID

ID

102193

102198

142621

102059

102064

143287

102070

102040

146583

102084

146563

102093

143108

102103











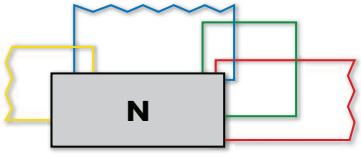

145579

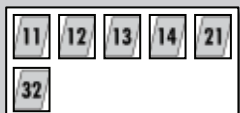
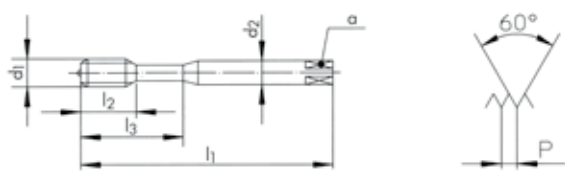
111493

145578











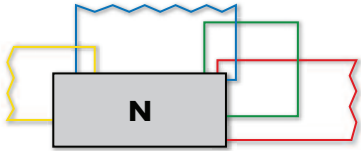



\* 111494

Δ ISO 1 4H = 6.70



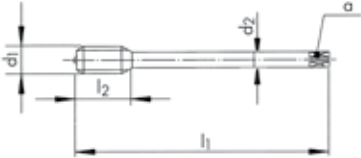







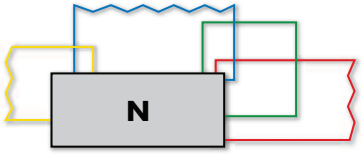



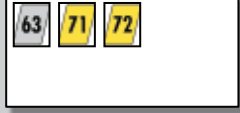

										N320-4	N320V-4	N320-4	N320-4				
																	
N320-4																	
N320V-4	 <b>V</b>																
																	
																	
Ø d <sub>1</sub> M	P mm	l <sub>1</sub> mm	l <sub>2</sub> mm	l <sub>3</sub> mm	d <sub>2</sub> mm	a mm				ID	6H + mm	ID	6H + mm	ID	6H + mm	ID	
*2	0.40	45	8.0		2.8	2.1	2	1.60		101457	0.019	143584	0.019				
2.5	0.45	50	10.0		2.8	2.1	3	2.05		101482	0.020	150522	0.020				
3	0.50	56	12.0	18	3.5	2.7	3	2.50		101486	0.020	143116	0.020	101489	0.036	101488	
3.5	0.60	56	13.0	20	4.0	3.0	3	2.95		101490	0.021						
4	0.70	63	14.0	21	4.5	3.4	3	3.35		101494	0.022	143087	0.022	101496	0.041	111522	
5	0.80	70	15.0	25	6.0	4.9	3	4.25		101498	0.024	143088	0.024	101500	0.044	111523	
6	1.00	80	17.0	30	6.0	4.9	3	5.00		101502	0.026	143089	0.026	101504	0.050	111524	
8	1.25	90	20.0	35	8.0	6.2	3	6.80		101505	0.028	143604	0.028				

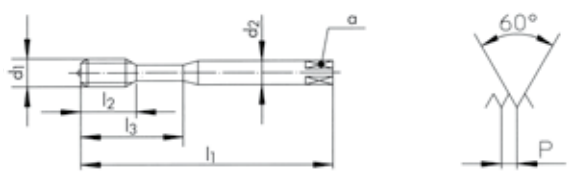
\* N320-3 / N320V-3











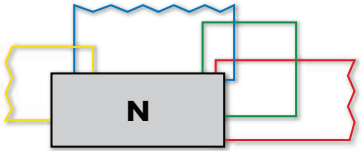









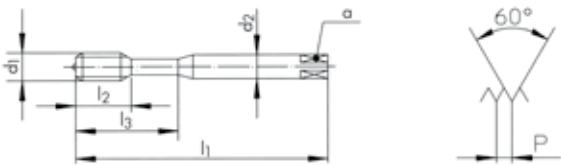







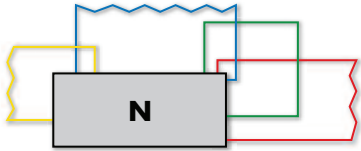





									N420-4	N420V-4	N420-4	N420-4																				
									   																							
N420-4		<table border="1"> <tr> <td>61</td> <td>63</td> <td>71</td> <td>72</td> <td>73</td> </tr> <tr> <td>81</td> <td colspan="4"></td> </tr> </table>							61	63	71	72	73	81					<table border="1"> <tr> <td>11</td> <td>12</td> <td>13</td> <td>14</td> <td>21</td> </tr> <tr> <td>32</td> <td colspan="4"></td> </tr> </table>				11	12	13	14	21	32				
61	63	71	72	73																												
81																																
11	12	13	14	21																												
32																																
N420V-4	 <b>V</b>								   																							
 									<table border="1"> <tr> <td><b>B</b> 4 x P</td> <td><b>B</b> 4 x P</td> <td><b>B</b> 4 x P</td> <td><b>B</b> 4 x P</td> </tr> <tr> <td><b>ISO 3 6G</b></td> <td><b>ISO 3 6G</b></td> <td><b>7G</b></td> <td><b>6H +0.1mm</b></td> </tr> </table>				<b>B</b> 4 x P	<b>B</b> 4 x P	<b>B</b> 4 x P	<b>B</b> 4 x P	<b>ISO 3 6G</b>	<b>ISO 3 6G</b>	<b>7G</b>	<b>6H +0.1mm</b>												
<b>B</b> 4 x P	<b>B</b> 4 x P	<b>B</b> 4 x P	<b>B</b> 4 x P																													
<b>ISO 3 6G</b>	<b>ISO 3 6G</b>	<b>7G</b>	<b>6H +0.1mm</b>																													
$\varnothing d_1$ <b>M</b>	<b>P</b> mm	$l_1$ mm	$l_2$ mm	$d_2$ mm	$\alpha$ mm				<b>ID</b>	<b>6H</b> + mm	<b>ID</b>	<b>6H</b> + mm	<b>ID</b>	<b>6H</b> + mm	<b>ID</b>																	
8	1.25	90	20.0	6.0	4.9	3	6.80	102194	0.028	145246	0.028	102199	0.052	102196																		
10	1.50	100	22.0	7.0	5.5	3	8.50	102060	0.032	143726	0.032	102065	0.060	102062																		
12	1.75	110	24.0	9.0	7.0	3	10.30	102071	0.034	145655	0.034	102076	0.066	102073																		
16	2.00	110	30.0	12.0	9.0	3	14.00	135531	0.038	162795	0.038	102094	0.072	102091																		

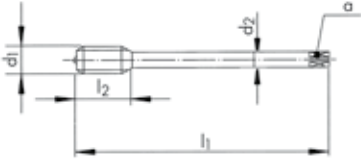









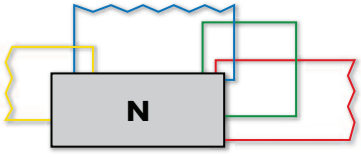



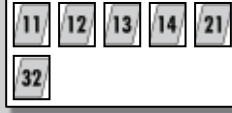

									N321-4	N330-4	N330V-4	
									  			
N321-4												
N330-4												
N330V-4												
												
												
Ø d <sub>1</sub> M	P mm	l <sub>1</sub> mm	l <sub>2</sub> mm	l <sub>3</sub> mm	d <sub>2</sub> mm	a mm		6H 	ID	ID	ID	
*1	0.25	40	5.5		2.5	2.1	2	0.75		101558		
*1.1	0.25	40	5.5		2.5	2.1	2	0.85		* 101559		
*1.2	0.25	40	5.5		2.5	2.1	2	0.95		101560		
*1.4	0.30	40	7.0		2.5	2.1	2	1.10		101561		
*1.6	0.35	40	8.0		2.5	2.1	2	1.25		101562	151246	
*1.7	0.35	40	8.0		2.5	2.1	2	1.35		* 101563		
*2	0.40	45	8.0		2.8	2.1	2	1.60	101552	105125	101572	
*2.2	0.45	45	9.0		2.8	2.1	2	1.75		* 105126		
*2.3	0.40	45	9.0		2.8	2.1	2	1.90		* 105127		
2.5	0.45	50	10.0		2.8	2.1	*3	2.05	101553	101565	101573	
2.6	0.45	50	10.0		2.8	2.1	2	2.15		* 101566		
3	0.50	56	12.0	18	3.5	2.7	*3	2.50	101555	101567	101574	
3.5	0.60	56	13.0	20	4.0	3.0	2	2.90		101568		
4	0.70	63	14.0	21	4.5	3.4	3	3.30	101557	101569	101576	
5	0.80	70	15.0	25	6.0	4.9	3	4.20		101570	101577	
6	1.00	80	17.0	30	6.0	4.9	3	5.00		101571	101578	
<p>* N321-3 / N330-3 / N330V-3  * N330-4 =  2</p> <p>* N330V-4 =  2</p>									<p>≤ M1.5 </p>			

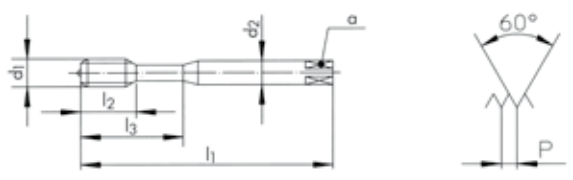







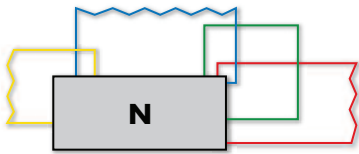





























									N420-4	N421-4	N430-4	N430V-4
N420-4												
N421-4												
N430-4												
N430V-4												
$\varnothing d_1$	P	$l_1$	$l_2$	$d_2$	$\alpha$		$6H$		ID	ID	ID	ID
M	mm	mm	mm	mm	mm		$\pm 0.2$					
4	0.70	63	14.0	2.8	2.1	3	3.30		102293			
5	0.80	70	15.0	3.5	2.7	3	4.20		102294			
6	1.00	80	17.0	4.5	3.4	3	5.00		102295			
8	1.25	90	20.0	6.0	4.9	3	6.80	102197	102296	102301	102306	
10	1.50	100	22.0	7.0	5.5	3	8.50	102063	102286	102297	102302	
12	1.75	110	24.0	9.0	7.0	3	10.20	102074	102287	102298	102303	
14	2.00	110	28.0	11.0	9.0	3	12.00		* 102288			
16	2.00	110	30.0	12.0	9.0	3	14.00	102092	102289			

									N350-3	N350V-3		
												
N350-3												
N350V-3	 											
												
												
												
												
Ø d <sub>1</sub> M	P mm	l <sub>1</sub> mm	l <sub>2</sub> mm	l <sub>3</sub> mm	d <sub>2</sub> mm	a mm			ID	ID		
2	0.40	45	8.0		2.8	2.1	2	1.60	101580	101593		
2.3	0.40	45	9.0		2.8	2.1	2	1.90	101581			
2.5	0.45	50	10.0		2.8	2.1	2	2.05	101582	101594		
2.6	0.45	50	10.0		2.8	2.1	2	2.15	101583			
3	0.50	56	12.0	18	3.5	2.7	2	2.50	101584	101595		
3.5	0.60	56	13.0	20	4.0	3.0	2	2.90	101585			
4	0.70	63	14.0	21	4.5	3.4	2	3.30	101587	101596		
5	0.80	70	15.0	25	6.0	4.9	3	4.20	101589	101597		
6	1.00	80	17.0	30	6.0	4.9	3	5.00	101591	101598		
8	1.25	90	20.0	35	8.0	6.2	3	6.80	101592	146810		
10	1.50	100	22.0	39	10.0	8.0	3	8.50	101579	147217		

								N450-3	N450V-3		
								<p><b>N450-3</b>  </p> <p><b>N450V-3</b>   </p>			
											
											
 											
											
$\varnothing d_1$ M	P mm	$l_1$ mm	$l_2$ mm	$d_2$ mm	$\alpha$ mm			ID	ID		
8	1.25	90	20.0	6.0	4.9	3	6.80	102327	102334		
10	1.50	100	22.0	7.0	5.5	3	8.50	102314	102329		
12	1.75	110	24.0	9.0	7.0	3	10.20	102317	102330		
14	2.00	110	28.0	11.0	9.0	3	12.00	102319	145487		
16	2.00	110	30.0	12.0	9.0	3	14.00	102321	102331		
20	2.50	140	36.0	16.0	12.0	4	17.50	102324	102332		
24	3.00	160	39.0	18.0	14.5	4	21.00	102325	102333		

									N360-3	N360V-3	N360TN-3	N360TC-3
												
N360-3												
N360V-3	 <b>V</b>											
N360TN-3	 <b>TiN</b>											
N360TC-3	 <b>TiCN</b>											
												
									<b>ISO 2 6H</b>	<b>ISO 2 6H</b>	<b>ISO 2 6H</b>	<b>ISO 2 6H</b>
Ø d <sub>1</sub> M	P mm	l <sub>1</sub> mm	l <sub>2</sub> mm	l <sub>3</sub> mm	d <sub>2</sub> mm	a mm			ID	ID	ID	ID
2	0.40	45	7.0		2.8	2.1	2	1.60	101618	101708	101697	146842
2.2	0.45	45	8.0		2.8	2.1	2	1.75	101619			
2.3	0.40	45	8.0		2.8	2.1	2	1.90	101620			
2.5	0.45	50	9.0		2.8	2.1	2	2.05	101622	101709	101698	101689
2.6	0.45	50	9.0		2.8	2.1	2	2.15	101623	101710		
3	0.50	56	5.5	18	3.5	2.7	3	2.50	101626	101711	101699	101690
3.5	0.60	56	6.5	20	4.0	3.0	3	2.90	101630	142625		
4	0.70	63	7.5	21	4.5	3.4	3	3.30	101635	101713	101700	101691
4.5	0.75	70	9.0	25	6.0	4.9	3	3.75	101639			
5	0.80	70	9.0	25	6.0	4.9	3	4.20	101644	101715	101701	101692
6	1.00	80	11.0	30	6.0	4.9	3	5.00	101652	101717	101703	101693
7	1.00	80	11.0	30	7.0	5.5	3	6.00	101656	101718		
8	1.25	90	12.5	35	8.0	6.2	3	6.80	101663	101721	101705	101694
9	1.25	90	12.5	35	9.0	7.0	3	7.80	101668			
10	1.50	100	14.0	39	10.0	8.0	3	8.50	101612	101707	101696	101688





<b>N460-3</b>		     
<b>N460V-3</b>	 	     
<b>N460TN-3</b>	 	        
<b>N460TC-3</b>	 	          





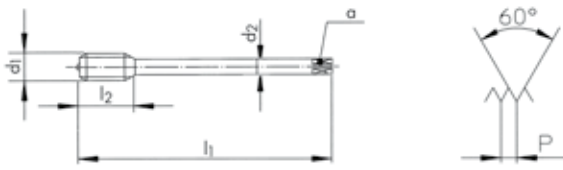





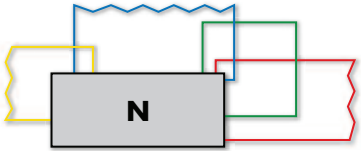







**N460-3      N460V-3      N460TN-3      N460TC-3**





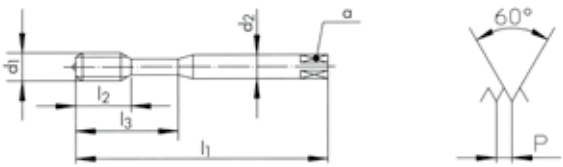



**ISO 2 6H      ISO 2 6H      ISO 2 6H      ISO 2 6H**

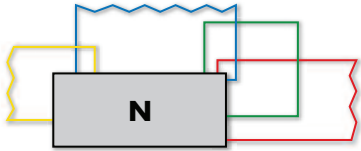

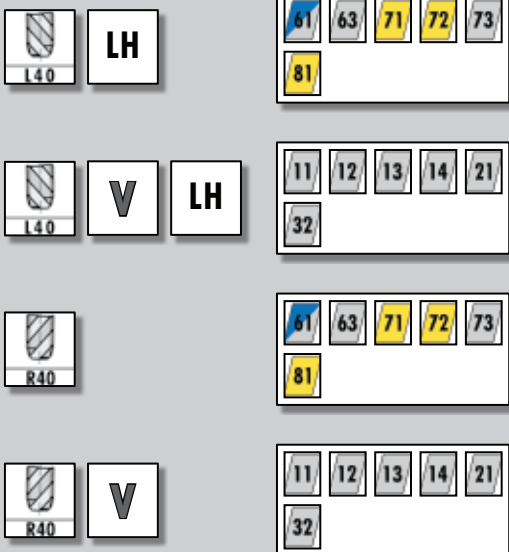

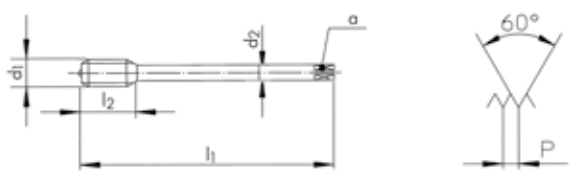
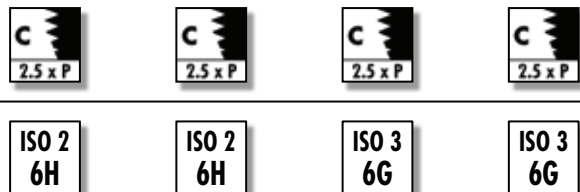





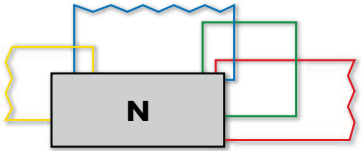

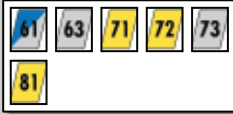

$\varnothing d_1$ M	P mm	$l_1$ mm	$l_2$ mm	$d_2$ mm	$\alpha$ mm			ID	ID	ID	ID
5	0.80	70	9.0	3.5	2.7	3	4.20	102410	102489	160682	
6	1.00	80	11.0	4.5	3.4	3	5.00	102411	102491	152850	
8	1.25	90	12.5	6.0	4.9	3	6.80	102412	102492	152849	
10	1.50	100	14.0	7.0	5.5	3	8.50	102351	102461	150242	158687
12	1.75	110	14.0	9.0	7.0	3	10.20	102359	102465	102449	102438
14	2.00	110	14.0	11.0	9.0	3	12.00	102369	102468	102451	111615
16	2.00	110	18.0	12.0	9.0	3	14.00	102376	102471	102453	102440
18	2.50	125	21.0	14.0	11.0	3	15.50	102383	102473		
20	2.50	140	24.0	16.0	12.0	4	17.50	102389	102475	102454	143280
22	2.50	140	24.0	18.0	14.5	4	19.50	102394	102477		
24	3.00	160	27.0	18.0	14.5	4	21.00	102398	102480	143119	150018
27	3.00	160	27.0	20.0	16.0	4	24.00	175423	102481		
30	3.50	180	30.0	22.0	18.0	4	26.50	150246	102482		
33	3.50	180	33.0	25.0	20.0	4	29.50	167621	102483		
36	4.00	200	36.0	28.0	22.0	5	32.00	143914	102484		
39	4.00	200	40.0	32.0	24.0	5	35.00	175424	102485		
42	4.50	200	40.0	32.0	24.0	5	37.50	169122	102486		
45	4.50	220	44.0	36.0	29.0	5	40.50		102487		
48	5.00	250	48.0	36.0	29.0	5	43.00		102488		
52	5.00	250	52.0	40.0	32.0	5	47.00		110228		
56	5.50	280	56.0	45.0	35.0	6	50.50		102490		
64	6.00	315	64.0	50.0	39.0	6	58.00		143805		



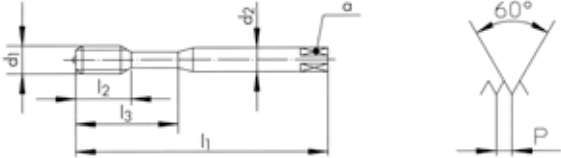







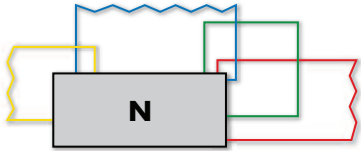

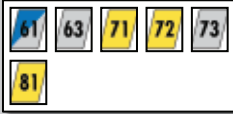









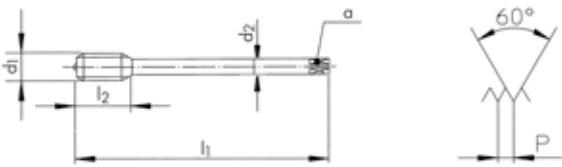

										N360-3 LH	N360V-3 LH	N360-3	N360V-3	
														
N360-3 LH		<b>LH</b>												
N360V-3 LH		<b>V LH</b>												
N360-3														
N360V-3		<b>V</b>												
														
														
Ø d <sub>1</sub> M	P mm	l <sub>1</sub> mm	l <sub>2</sub> mm	l <sub>3</sub> mm	d <sub>2</sub> mm	a mm		6H → ←	ID	ID	ID + mm	6H + mm	ID + mm	
2	0.40	45	7.0		2.8	2.1	2	1.60			101617	0.019	146000	0.019
2.5	0.45	50	9.0		2.8	2.1	2	2.05			101621	0.020	143294	0.020
3	0.50	56	5.5	18	3.5	2.7	3	2.50	101627	146811	101625	0.020	104816	0.020
3.5	0.60	56	6.5	20	4.0	3.0	3	2.95			101629	0.021	125829	0.021
4	0.70	63	7.5	21	4.5	3.4	3	3.30	101637	162540	101634	0.022	104817	0.022
5	0.80	70	9.0	25	6.0	4.9	3	4.20	101646	144003	101643	0.024	104818	0.024
6	1.00	80	11.0	30	6.0	4.9	3	5.00	101654	144004	101669	0.026	104819	0.026
8	1.25	90	12.5	35	8.0	6.2	3	6.80	101666	143925	101662	0.028	104820	0.028
10	1.50	100	14.0	39	10.0	8.0	3	8.50	101615	143587	101611	0.032	104821	0.032











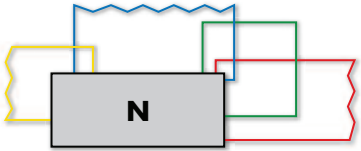

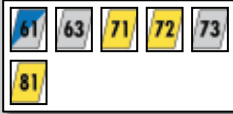





								N460-3 LH	N460V-3 LH	N460-3	N460V-3		
													
													
													
$\varnothing d_1$ M	P mm	$l_1$ mm	$l_2$ mm	$d_2$ mm	$\alpha$ mm		$6H$ $\rightarrow \leftarrow$	ID	ID	ID	$6H$ + mm	ID	$6H$ + mm
12	1.75	110	14.0	9.0	7.0	3	10.20	102362	146354	102358	0.034	143602	0.034
14	2.00	110	14.0	11.0	9.0	3	12.00			102368	0.038	144712	0.038
16	2.00	110	18.0	12.0	9.0	3	14.00	102378	143439	102375	0.038	150197	0.038
20	2.50	140	24.0	16.0	12.0	4	17.50	102390	146564	102388	0.042	145420	0.042



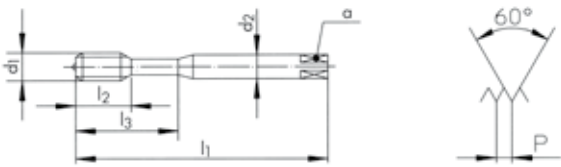





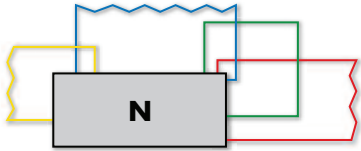

									N360-3	N360-3	N360V-3	N360-3		
														
N360-3														
N360V-3	 													
														
									ISO 1 4H	7G	7G	6H +0.1mm		
Ø d <sub>1</sub> M	P mm	l <sub>1</sub> mm	l <sub>2</sub> mm	l <sub>3</sub> mm	d <sub>2</sub> mm	a mm			ID	ID	6H + mm	ID	6H + mm	ID
3	0.50	56	5.5	18	3.5	2.7	3	2.50	101624	101628	0.036	144311	0.036	160847
4	0.70	63	7.5	21	4.5	3.4	3	3.30	101633	101638	0.041	144192	0.041	101636
5	0.80	70	9.0	25	6.0	4.9	3	4.20	101642	101647	0.044	143208	0.044	101645
6	1.00	80	11.0	30	6.0	4.9	3	5.00	101651	101655	0.050	146709	0.050	101653
8	1.25	90	12.5	35	8.0	6.2	3	△ 6.80	101661	101667	0.052	146267	0.052	101664
10	1.50	100	14.0	39	10.0	8.0	3	8.50	101610	101616	0.060	142547	0.060	101613

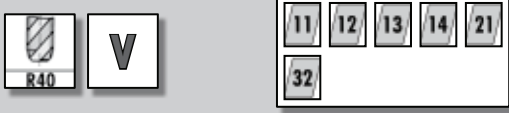
△ ISO 1  
4H =  6.70

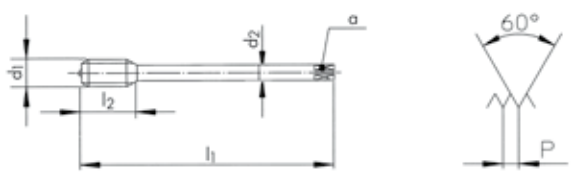









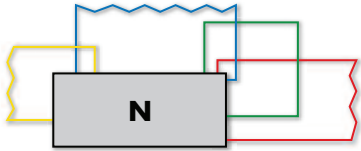

									N460-3	N460-3	N460V-3	N460-3		
									<b>N460-3</b>  					
<b>N460V-3</b>   														
														
														
$\varnothing d_1$	P	$l_1$	$l_2$	$d_2$	a				ID	ID	6H	ID	6H	ID
M	mm	mm	mm	mm	mm		$\rightarrow \leftarrow$				+ mm		+ mm	
12	1.75	110	14.0	9.0	7.0	3	10.20		* 124987	102363	0.066	142532	0.066	102360
16	2.00	110	18.0	12.0	9.0	3	14.00			102379	0.072	144956	0.072	102377

									N360-5	N360V-5	N361-3	N362V-3
												
N360-5												
N360V-5	 											
N361-3	 											
N362V-3	  											
												
												
												
Ø d <sub>1</sub> M	P mm	l <sub>1</sub> mm	l <sub>2</sub> mm	l <sub>3</sub> mm	d <sub>2</sub> mm	a mm			ID	ID	ID	ID
2	0.40	45	7.0		2.8	2.1	2	1.60	158079	150058		
3	0.50	56	5.5	18	3.5	2.7	3	2.50	104809	142646	101735	
4	0.70	63	7.5	21	4.5	3.4	3	3.30	104810	142647	101736	101741
5	0.80	70	9.0	25	6.0	4.9	3	4.20	104811	142648	101737	101742
6	1.00	80	11.0	30	6.0	4.9	3	5.00	104812	142649	101738	101743
8	1.25	90	12.5	35	8.0	6.2	3	6.80	104813	142650	101739	101744
10	1.50	100	14.0	39	10.0	8.0	3	8.50	104814	124899	101734	101740

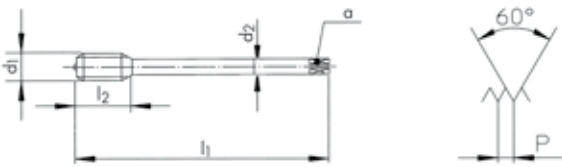
								N460-5	N460V-5	N461-3	N462V-3
											
											
											
											
											
											
											
											
$\varnothing d_1$ M	P mm	$l_1$ mm	$l_2$ mm	$d_2$ mm	$\alpha$ mm			ID	ID	ID	ID
12	1.75	110	14.0	9.0	7.0	3	10.20	104815	142651	102506	102512
14	2.00	110	14.0	11.0	9.0	3	12.00			* 102507	102513
16	2.00	110	18.0	12.0	9.0	3	14.00			* 102508	102514
18	2.50	125	21.0	14.0	11.0	3	15.50			* 111614	102515
20	2.50	140	24.0	16.0	12.0	4	17.50				102516
24	3.00	160	27.0	18.0	14.5	4	21.00				102517
27	3.00	160	27.0	20.0	16.0	4	24.00				159244
30	3.50	180	30.0	22.0	18.0	4	26.50				143090



										N520-4	N520V-4	N520TN-4	
N520-4													
N520V-4		<b>V</b>											
N520TN-4		<b>TiN</b>											
Ø d <sub>1</sub> M	P mm	l <sub>1</sub> mm	l <sub>2</sub> mm	l <sub>3</sub> mm	d <sub>2</sub> mm	a mm				ID	ID	ID	
2.5	0.45	100	10.0		2.8	2.1	3	2.05		102594	142623		
3	0.50	112	12.0	18	3.5	2.7	3	2.50		102595	143399	162790	
4	0.70	112	14.0	21	4.5	3.4	3	3.30		102596	143400	146837	
5	0.80	125	15.0	25	6.0	4.9	3	4.20		102597	142654	150113	
6	1.00	125	17.0	30	6.0	4.9	3	5.00		102598	143137	148821	

									N620-4	N620V-4	N620TN-4
									N620-4		
N620V-4	 <b>V</b>										
N620TN-4	 <b>TiN</b>										
											
									<b>ISO 2 6H</b>	<b>ISO 2 6H</b>	<b>ISO 2 6H</b>
$\varnothing d_1$ M	P mm	$l_1$ mm	$l_2$ mm	$d_2$ mm	$\alpha$ mm			ID	ID	ID	
4	0.70	112	14.0	2.8	2.1	3	3.30	102619	142582	146442	
5	0.80	125	15.0	3.5	2.7	3	4.20	102620	142657	146443	
6	1.00	125	17.0	4.5	3.4	3	5.00	102621	142658	144591	
8	1.25	140	20.0	6.0	4.9	3	6.80	102622	143401	146262	
10	1.50	160	22.0	7.0	5.5	3	8.50	102614	142660	146849	
12	1.75	180	24.0	9.0	7.0	3	10.20	102615	143127	146295	
14	2.00	180	28.0	11.0	9.0	3	12.00	102616	151905		
16	2.00	200	30.0	12.0	9.0	3	14.00	102617	143106	143574	
20	2.50	224	36.0	16.0	12.0	3	17.50	102618	143596		



										N560-3	N560V-3	N560TN-3						
										N560-3								
N560V-3																		
N560TN-3																		
Ø d <sub>1</sub> M	P mm	l <sub>1</sub> mm	l <sub>2</sub> mm	l <sub>3</sub> mm	d <sub>2</sub> mm	a mm			ID	ID	ID							
2.5	0.45	100	9.0		2.8	2.1	2	2.05	102600	102607								
3	0.50	112	5.5	18	3.5	2.7	3	2.50	102601	102608	142663							
4	0.70	112	7.5	21	4.5	3.4	3	3.30	102602	102609	142664							
5	0.80	125	9.0	25	6.0	4.9	3	4.20	102603	102610	142665							
6	1.00	125	11.0	30	6.0	4.9	3	5.00	102604	102611	142666							
8	1.25	140	12.5	35	8.0	6.2	3	6.80	102605	102612	142667							
10	1.50	160	14.0	39	10.0	8.0	3	8.50	102599	102606	142668							

# M ISO DIN 13

HSSE

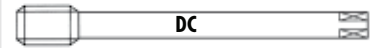









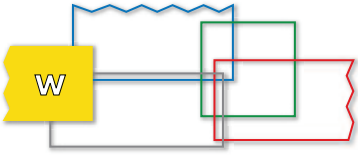

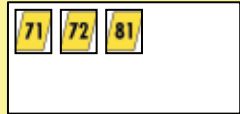





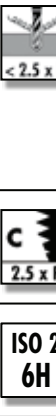





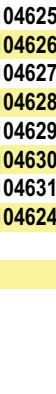
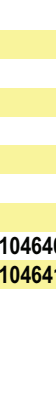
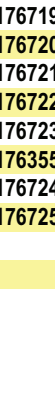
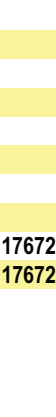

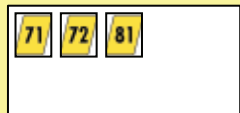



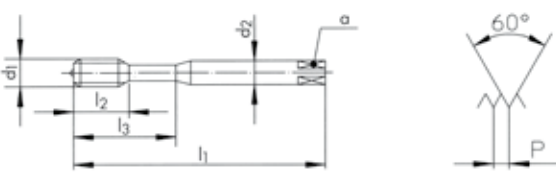











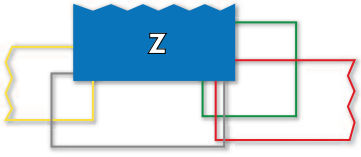



								N660-3	N660V-3	N660TN-3	
N660-3											
N660V-3											
N660TN-3											
$\varnothing d_1$ M	P mm	$l_1$ mm	$l_2$ mm	$d_2$ mm	$\alpha$ mm			ID	ID	ID	
6	1.00	125	11.0	4.5	3.4	3	5.00	162792	115657		
8	1.25	140	12.5	6.0	4.9	3	6.80	162793	115544		
10	1.50	160	14.0	7.0	5.5	3	8.50	162794	135539	173484	
12	1.75	180	14.0	9.0	7.0	3	10.20	102623	102626	142669	
14	2.00	180	14.0	11.0	9.0	3	12.00	162253	147500		
16	2.00	200	18.0	12.0	9.0	3	14.00	102624	102627	142670	
20	2.50	224	24.0	16.0	12.0	4	17.50	102625	102628		

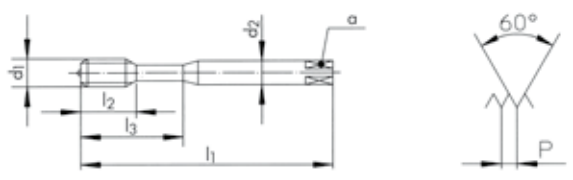

									W320-4	W420-4	W320DL-4	W420DL-4	
W320-4		71 72 81											
W420-4		71 72 81											
W320DL-4		DL	71 72 81							NEW			
W420DL-4		DL	71 72 81							NEW			
$\varnothing d_1$ M	P mm	$l_1$ mm	$l_2$ mm	$l_3$ mm	$d_2$ mm	a mm			ID	ID	ID	ID	
*2	0.40	45	8.0		2.8	2.1	2	1.60	104612		176688		
2.5	0.45	50	10.0		2.8	2.1	2	2.05	104613		176689		
2.6	0.45	50	10.0		2.8	2.1	2	2.15	* 104614				
3	0.50	56	12.0	18	3.5	2.7	2	2.50	104615		176690		
3.5	0.60	56	13.0	20	4.0	3.0	2	2.90	* 104616				
4	0.70	63	14.0	21	4.5	3.4	2	3.30	104617		176691		
5	0.80	70	15.0	25	6.0	4.9	2	4.20	104618		176354		
6	1.00	80	17.0	30	6.0	4.9	2	5.00	104619		175590		
8	1.25	90	20.0		6.0	4.9	2	6.80		104636		176692	
10	1.50	100	22.0		7.0	5.5	2	8.50		104632		176693	
12	1.75	110	24.0		9.0	7.0	3	10.20		104633		176694	
16	2.00	110	30.0		12.0	9.0	3	14.00		104634		176695	

\* W320-3   
 \* W320DL-3

									W360-3	W460-3	W360DL-3	W460DL-3
									<b>W360-3</b>  			
<b>W460-3</b>  												
<b>W360DL-3</b>   												
<b>W460DL-3</b>   												
												
												
Ø d <sub>1</sub> M	P mm	l <sub>1</sub> mm	l <sub>2</sub> mm	l <sub>3</sub> mm	d <sub>2</sub> mm	a mm			ID	ID	ID	ID
2	0.40	45	7.0		2.8	2.1	2	1.60	104625		176719	
2.5	0.45	50	9.0		2.8	2.1	2	2.05	104626		176720	
3	0.50	56	5.5	18	3.5	2.7	2	2.50	104627		176721	
4	0.70	63	7.5	21	4.5	3.4	2	3.30	104628		176722	
5	0.80	70	9.0	25	6.0	4.9	2	4.20	104629		176723	
6	1.00	80	11.0	30	6.0	4.9	2	5.00	104630		176355	
8	1.25	90	12.5	35	8.0	6.2	2	6.80	104631		176724	
10	1.50	100	14.0	39	10.0	8.0	2	8.50	104624		176725	
12	1.75	110	14.0		9.0	7.0	3	10.20		104640		176726
16	2.00	110	18.0		12.0	9.0	3	14.00		104641		176727

										Z320V-4	Z420V-4	Z320VS-4	Z420VS-4						
Z320V-4		<b>V</b>	21 22 23 41 42 51	Z420V-4		<b>V</b>	21 22 23 41 42 51	Z320VS-4		<b>VS</b>	21 22 23 24 51 61	Z420VS-4		<b>VS</b>	21 22 23 24 51 61				
																			
										<b>ISO 2 6H</b>	<b>ISO 2 6H</b>	<b>ISO 2 6H</b>	<b>ISO 2 6H</b>						
$\varnothing d_1$ M P mm l <sub>1</sub> mm l <sub>2</sub> mm l <sub>3</sub> mm d <sub>2</sub> mm a mm  	<b>ID</b>	<b>ID</b>	<b>ID</b>	<b>ID</b>															
*1.6	0.35	40	8.0		2.5	2.1	2	1.25	<b>142671</b>										
*2	0.40	45	8.0		2.8	2.1	2	1.60	<b>111613</b>										
2.5	0.45	50	10.0		2.8	2.1	3	2.05	<b>111455</b>		<b>143683</b>								
2.6	0.45	50	10.0		2.8	2.1	3	2.15	<b>142672</b>										
3	0.50	56	12.0	18	3.5	2.7	3	2.50	<b>104669</b>		<b>104830</b>								
4	0.70	63	14.0	21	4.5	3.4	3	3.30	<b>104670</b>		<b>104831</b>								
5	0.80	70	15.0	25	6.0	4.9	3	4.20	<b>104671</b>		<b>104832</b>								
6	1.00	80	17.0	30	6.0	4.9	3	5.00	<b>104672</b>		<b>104833</b>								
8	1.25	90	20.0	35	8.0	6.2	3	6.80	<b>104673</b>		<b>104834</b>								
10	1.50	100	22.0	39	10.0	8.0	3	8.50	<b>104668</b>		<b>104835</b>								
12	1.75	110	24.0		9.0	7.0	3	10.20		<b>104723</b>		<b>104836</b>							
14	2.00	110	28.0		11.0	9.0	3	12.00		<b>142673</b>		<b>143684</b>							
16	2.00	110	30.0		12.0	9.0	3	14.00		<b>105068</b>		<b>111569</b>							
18	2.50	125	33.0		14.0	11.0	4	15.50		<b>142674</b>									
20	2.50	140	36.0		16.0	12.0	4	17.50		<b>105069</b>		<b>111570</b>							
22	2.50	140	36.0		18.0	14.5	4	19.50		<b>146003</b>									
24	3.00	160	39.0		18.0	14.5	4	21.00		<b>142675</b>									
30	3.50	180	45.0		22.0	18.0	4	26.50		<b>142676</b>									

\* Z320V-3



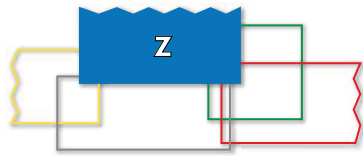

Z360V-3

Z362V-3

Z462V-3

Z360V-3

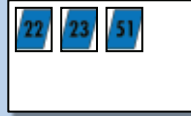

Z362V-3



Z462V-3

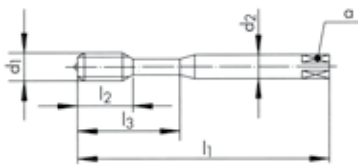
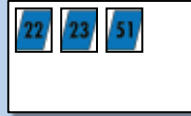

Ø d <sub>1</sub> M	P mm	l <sub>1</sub> mm	l <sub>2</sub> mm	l <sub>3</sub> mm	d <sub>2</sub> mm	a mm		
2	0.40	45	7.0		2.8	2.1	2	1.60
2.5	0.45	50	9.0		2.8	2.1	2	2.05
2.6	0.45	50	9.0		2.8	2.1	2	2.15
3	0.50	56	5.5	18	3.5	2.7	3	2.50
3.5	0.60	56	6.5	20	4.0	3.0	3	2.90
4	0.70	63	7.5	21	4.5	3.4	3	3.30
5	0.80	70	9.0	25	6.0	4.9	3	4.20
6	1.00	80	11.0	30	6.0	4.9	3	5.00
8	1.25	90	12.5	35	8.0	6.2	3	6.80
10	1.50	100	14.0	39	10.0	8.0	3	8.50
12	1.75	110	14.0		9.0	7.0	3	10.20
14	2.00	110	14.0		11.0	9.0	3	12.00
16	2.00	110	18.0		12.0	9.0	3	14.00
18	2.50	125	21.0		14.0	11.0	3	15.50
20	2.50	140	24.0		16.0	12.0	3	17.50
22	2.50	140	24.0		18.0	14.5	3	19.50
24	3.00	160	27.0		18.0	14.5	4	21.00
27	3.00	160	27.0		20.0	16.0	4	24.00
30	3.50	180	30.0		22.0	18.0	4	26.50
36	4.00	200	36.0		28.0	22.0	4	32.00
42	4.50	200	40.0		32.0	24.0	4	37.50

ID

ID

ID

104684  
104685  
104686  
104687

104688  
104689  
104690  
104691  
104692  
104683

104742  
104743  
104744  
104745  
104746  
104752  
104747  
104748  
104749  
104750  
104751

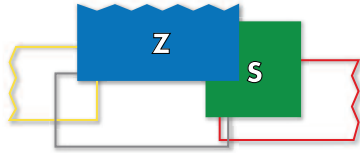

Z362VS-3    Z370VS-3    Z370VS-3    Z373VS-3



Z362VS-3



Z370VS-3



Z373VS-3

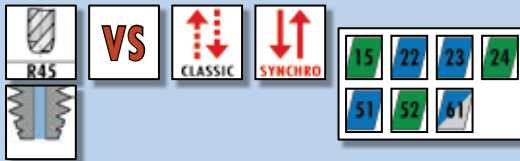



PM    PM    PM



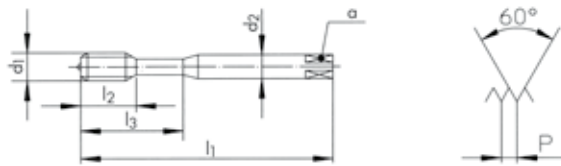

6HX    6HX    4HX    6HX



∅ d <sub>1</sub> M	P mm	l <sub>1</sub> mm	l <sub>2</sub> mm	l <sub>3</sub> mm	d <sub>2</sub> mm	a mm		
*3	0.50	56	5.5	18	3.5	2.7	3	2.50
4	0.70	63	7.5	21	4.5	3.4	3	3.30
5	0.80	70	9.0	25	6.0	4.9	3	4.20
6	1.00	80	11.0	30	6.0	4.9	3	5.00
8	1.25	90	12.5	35	8.0	6.2	3	6.80
10	1.50	100	14.0	39	10.0	8.0	3	8.50

ID	ID	ID
111504		
111505		
111506		
111507		
111508		
111509		









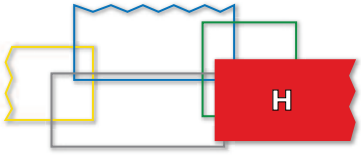

\* Z360VS-3





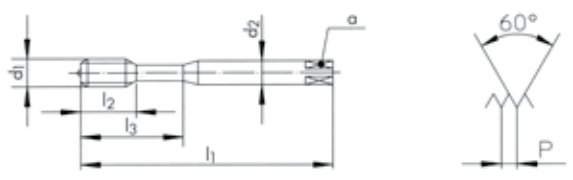





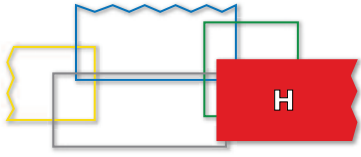

∅ d <sub>1</sub> M	P mm	l <sub>1</sub> mm	l <sub>2</sub> mm	l <sub>3</sub> mm	d <sub>2</sub> h <sub>6</sub> mm	a mm		
3	0.50	56	5.5	18	3.5(h <sub>9</sub> )	2.7	3	2.50
4	0.70	63	7.5	21	4.5(h <sub>9</sub> )	3.4	3	3.30
5	0.80	70	9.0	25	6.0	4.9	3	4.20
6	1.00	80	11.0	30	6.0	4.9	3	5.00
8	1.25	90	12.5	35	8.0	6.2	3	<sup>Δ</sup> 6.80
10	1.50	100	14.0	39	10.0	8.0	3	8.50

ID	ID	ID
162776	165324	165236
162777	165325	165237
162778	165326	165238
162779	165327	165239
162780	165328	165240
162781	165438	165241

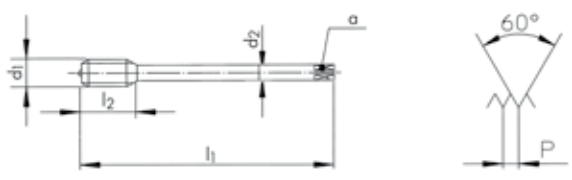
<sup>Δ</sup> 4HX =  = 6.70

									Z462VS-3	Z470VS-3	Z473VS-3	
<p><b>Z462VS-3</b></p>												
<p><b>Z470VS-3</b></p>												
<p><b>Z473VS-3</b></p>												
∅ d <sub>1</sub> M	P mm	l <sub>1</sub> mm	l <sub>2</sub> mm	d <sub>2</sub> mm	a mm			ID				
12	1.75	110	14.0	9.0	7.0	4	10.20	111510				
14	2.00	110	14.0	11.0	9.0	4	12.00	* 148169				
16	2.00	110	18.0	12.0	9.0	4	14.00	111511				
20	2.50	140	24.0	16.0	12.0	4	17.50	111512				
24	3.00	160	27.0	18.0	14.5	4	21.00	* 111620				
∅ d <sub>1</sub> M	P mm	l <sub>1</sub> mm	l <sub>2</sub> mm	d <sub>2</sub> h6 mm	a mm			ID	ID			
12	1.75	110	14.0	* 10.0	* 8.0	4	10.20	162782	165242			
14	2.00	110	14.0	* 12.0	* 9.0	4	12.00	162783	* 165243			
16	2.00	110	18.0	12.0	9.0	4	14.00	162784	165244			
18	2.50	125	21.0	14.0	11.0	4	15.50	170643				
20	2.50	140	24.0	16.0	12.0	4	17.50	162785	165234			
22	2.50	140	24.0	16.0	12.0	4	19.50	175190				
24	3.00	160	27.0	16.0	12.0	4	21.00	162786	165235			
* Norme DC / * DC Norm / * Norma DC												

										H320-4	H320TC-4		
										<p>H320-4  </p> <p>H320TC-4   </p>			
													
													
$\varnothing d_1$ M	P mm	$l_1$ mm	$l_2$ mm	$l_3$ mm	$d_2$ mm	$a$ mm			ID	ID			
2	0.40	45	8.0		2.8	2.1	2	1.60	101206	151836			
2.2	0.45	45	9.0		2.8	2.1	2	1.75	111801				
2.5	0.45	50	10.0		2.8	2.1	3	2.05	101207	148603			
3	0.50	56	12.0	18	3.5	2.7	3	2.50	101209	111836			
3.5	0.60	56	13.0	20	4.0	3.0	3	2.90	101210				
4	0.70	63	14.0	21	4.5	3.4	3	3.30	101211	111502			
4.5	0.75	70	15.0	25	6.0	4.9	3	3.75	101212				
5	0.80	70	15.0	25	6.0	4.9	3	4.20	101213	111458			
6	1.00	80	17.0	30	6.0	4.9	3	5.00	101215	111456			
8	1.25	90	20.0	35	8.0	6.2	3	6.80	101218	111453			
10	1.50	100	22.0	39	10.0	8.0	3	8.50	101205	110911			

								H420-4	H420TC-4						
															
H420-4															
H420TC-4	 <b>TiCN</b>														
															
															
Ø d <sub>1</sub> M	P mm	l <sub>1</sub> mm	l <sub>2</sub> mm	d <sub>2</sub> mm	α mm			ID	ID						
12	1.75	110	24.0	9.0	7.0	4	10.20	101275	110912						
14	2.00	110	28.0	11.0	9.0	4	12.00	101277							
16	2.00	110	30.0	12.0	9.0	4	14.00	101279	111612						
18	2.50	125	33.0	14.0	11.0	4	15.50	101281							
20	2.50	140	36.0	16.0	12.0	4	17.50	101284							
24	3.00	160	39.0	18.0	14.5	4	21.00	101286							
27	3.00	160	42.0	20.0	16.0	4	24.00	101287							
30	3.50	180	45.0	22.0	18.0	4	26.50	101288							
36	4.00	200	51.0	28.0	22.0	4	32.00	101289							



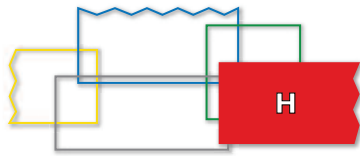

H350-3	H350-3	H350TC-3	
--------	--------	----------	--



H350-3



H350TC-3

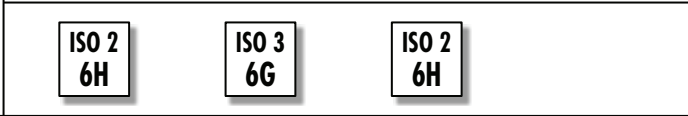
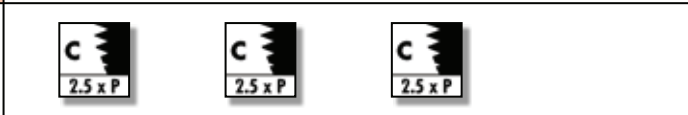
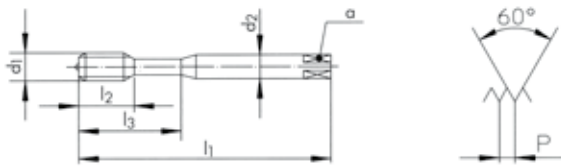

$\varnothing d_1$ M	P mm	$l_1$ mm	$l_2$ mm	$l_3$ mm	$d_2$ mm	a mm		$6H$ $\frac{\mu m}{\rightarrow \leftarrow}$
2	0.40	45	7.0		2.8	2.1	2	1.60
2.5	0.45	50	9.0		2.8	2.1	3	2.05
3	0.50	56	5.5	18	3.5	2.7	3	2.50
3.5	0.60	56	6.5	20	4.0	3.0	3	2.90
4	0.70	63	7.5	21	4.5	3.4	3	3.30
4.5	0.75	70	9.0	25	6.0	4.9	3	3.75
5	0.80	70	9.0	25	6.0	4.9	3	4.20
6	1.00	80	11.0	30	6.0	4.9	3	5.00
8	1.25	90	12.5	35	8.0	6.2	3	6.80
10	1.50	100	14.0	39	10.0	8.0	3	8.50

ID	ID $6H$ + mm	ID
101238		146451
101239		144957
101242	101241 0.020	111835
101243		
101245	101244 0.022	111607
101246		
101248	101247 0.024	111610
101251	101250 0.026	111500
101255	101254 0.028	110963
101237	101236 0.032	111454

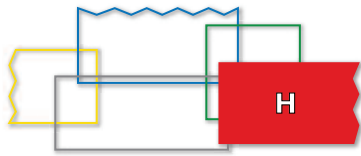

H450-3

H450-3

H450TC-3

H450-3



H450TC-3

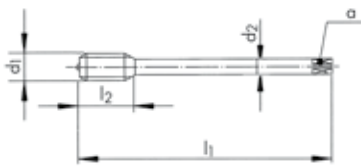

Ø d <sub>1</sub> M	P mm	l <sub>1</sub> mm	l <sub>2</sub> mm	d <sub>2</sub> mm	α mm		6H → ←
12	1.75	110	14.0	9.0	7.0	4	10.20
14	2.00	110	14.0	11.0	9.0	4	12.00
16	2.00	110	18.0	12.0	9.0	4	14.00
18	2.50	125	21.0	14.0	11.0	4	15.50
20	2.50	140	24.0	16.0	12.0	4	17.50
22	2.50	140	24.0	18.0	14.5	4	19.50
24	3.00	160	27.0	18.0	14.5	4	21.00
27	3.00	160	27.0	20.0	16.0	4	24.00
30	3.50	180	30.0	22.0	18.0	4	26.50
36	4.00	200	36.0	28.0	22.0	4	32.00
42	4.50	200	40.0	32.0	24.0	4	37.50

ID

ID

6H  
+ mm

ID

101305

101304

0.034

111501

101307

101309

111605

101311

101313

101315

101318

101320

101323

101324

101325

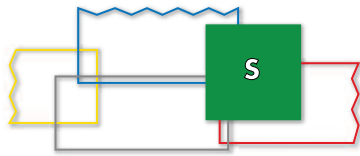

S320VS-4



VS



S420VS-4



VS



S320VS-4

S320VS-4

S420VS-4

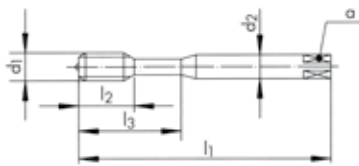

$\varnothing d_1$ M	P mm	$l_1$ mm	$l_2$ mm	$l_3$ mm	$d_2$ mm	$a$ mm		
3	0.50	56	12.0	18	3.5	2.7	3	2.50
4	0.70	63	14.0	21	4.5	3.4	3	3.30
5	0.80	70	15.0	25	6.0	4.9	3	4.20
6	1.00	80	17.0	30	6.0	4.9	3	5.00
8	1.25	90	20.0	35	8.0	6.2	3	$\Delta$ 6.80
10	1.50	100	22.0	39	10.0	8.0	3	8.50
12	1.75	110	24.0		9.0	7.0	4	10.20
14	2.00	110	30.0		11.0	9.0	4	12.50
16	2.00	110	30.0		12.0	9.0	4	14.00
20	2.50	140	36.0		16.0	12.0	4	17.50

ID	ID	ID
111596	* 165318	
111597	165319	
111598	165320	
111599	165321	
111600	165322	
111601	165323	
		111602
		* 162537
		111603
		111604



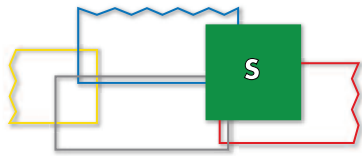

S360VS-3



S460VS-3



## aero

SA390-3

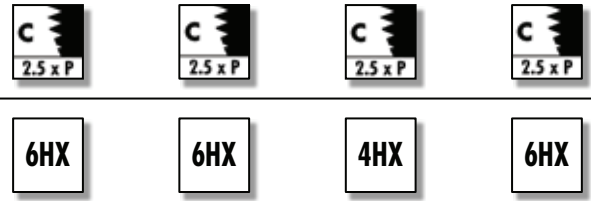
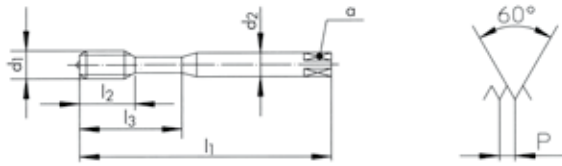

$\varnothing d_1$ M	P mm	$l_1$ mm	$l_2$ mm	$l_3$ mm	$d_2$ mm	$a$ mm		
3	0.50	56	5.5	18	3.5	2.7	3	2.50
4	0.70	63	7.5	21	4.5	3.4	3	3.30
5	0.80	70	9.0	25	6.0	4.9	3	4.20
6	1.00	80	11.0	30	6.0	4.9	3	5.00
8	1.25	90	12.5	35	8.0	6.2	3	6.80
10	1.50	100	14.0	39	10.0	8.0	3	8.50
12	1.75	110	14.0		9.0	7.0	4	10.20
14	2.00	110	14.0		11.0	9.0	4	12.00
16	2.00	110	18.0		12.0	9.0	4	14.00
20	2.50	140	24.0		16.0	12.0	4	17.50
24	3.00	160	27.0		18.0	14.5	4	21.00

ID	ID
111513	
111514	
111515	
111516	
111517	
111518	
	111519
	148171
	111520
	111521
	111606

$\varnothing d_1$ M	P mm	$l_1$ mm	$l_2$ mm	$d_2$ mm	$a$ mm		
4	0.70	63	14.0	4.5	3.4	3	3.30
5	0.80	70	15.0	6.0	4.9	3	4.20
6	1.00	80	20.0	6.0	4.9	3	5.00
8	1.25	90	25.0	8.0	6.2	3	$\Delta$ 6.80
10	1.50	100	30.0	10.0	8.0	3	8.50
12	1.75	110	35.0	12.0	9.0	4	10.20
14	2.00	110	40.0	16.0	12.0	4	12.00
16	2.00	110	40.0	16.0	12.0	4	14.00

ID	ID
149673	149674
149693	149694
149707	149708
149736	149737
149754	149755
	149775
	* 149792
	* 149816



## aero

										SA320-4	SA350-3	TL320VS-4	TL351VS-3																																																																																												
<div style="display: flex; justify-content: space-between;"> <div style="width: 45%;"> <p><b>SA320-4</b> </p> <p><b>SA350-3</b> </p> </div> <div style="width: 45%;"> <p><b>TL320VS-4</b> </p> <p><b>TL351VS-3</b> </p> </div> </div>																																																																																																									
<div style="display: flex; justify-content: space-between;"> <div style="width: 45%;"> <p><b>TL320VS-4</b> </p> <p><b>TL351VS-3</b> </p> </div> <div style="width: 45%;"> <p><b>SA320-4</b> </p> <p><b>SA350-3</b> </p> </div> </div>																																																																																																									
<table border="1"> <thead> <tr> <th><math>\varnothing d_1</math></th> <th>P</th> <th><math>l_1</math></th> <th><math>l_2</math></th> <th><math>l_3</math></th> <th><math>d_2</math></th> <th>a</th> <th></th> <th></th> <th></th> </tr> <tr> <th>M</th> <th>mm</th> <th>mm</th> <th>mm</th> <th>mm</th> <th>mm</th> <th>mm</th> <th></th> <th></th> <th></th> </tr> </thead> <tbody> <tr><td>3</td><td>0.50</td><td>56</td><td>12.0</td><td></td><td>3.5</td><td>2.7</td><td>3</td><td>2.50</td><td></td></tr> <tr><td>4</td><td>0.70</td><td>63</td><td>14.0</td><td></td><td>4.5</td><td>3.4</td><td>3</td><td>3.30</td><td></td></tr> <tr><td>5</td><td>0.80</td><td>70</td><td>15.0</td><td></td><td>6.0</td><td>4.9</td><td>3</td><td>4.20</td><td></td></tr> <tr><td>6</td><td>1.00</td><td>80</td><td>15.0</td><td>23</td><td>6.0</td><td>4.9</td><td>3</td><td>5.00</td><td></td></tr> <tr><td>8</td><td>1.25</td><td>90</td><td>18.0</td><td>29</td><td>8.0</td><td>6.2</td><td>3</td><td>6.70</td><td></td></tr> <tr><td>10</td><td>1.50</td><td>100</td><td>20.0</td><td>33</td><td>10.0</td><td>8.0</td><td>3</td><td>8.50</td><td></td></tr> </tbody> </table>										$\varnothing d_1$	P	$l_1$	$l_2$	$l_3$	$d_2$	a				M	mm	mm	mm	mm	mm	mm				3	0.50	56	12.0		3.5	2.7	3	2.50		4	0.70	63	14.0		4.5	3.4	3	3.30		5	0.80	70	15.0		6.0	4.9	3	4.20		6	1.00	80	15.0	23	6.0	4.9	3	5.00		8	1.25	90	18.0	29	8.0	6.2	3	6.70		10	1.50	100	20.0	33	10.0	8.0	3	8.50		<table border="1"> <thead> <tr> <th>B</th> <th>C</th> <th>B</th> <th>C</th> </tr> <tr> <th>4 x P</th> <th>2.5 x P</th> <th>4 x P</th> <th>2.5 x P</th> </tr> </thead> <tbody> <tr><td><b>4HX</b></td><td><b>4HX</b></td><td><b>4HX</b></td><td><b>4HX</b></td></tr> </tbody> </table>				B	C	B	C	4 x P	2.5 x P	4 x P	2.5 x P	<b>4HX</b>	<b>4HX</b>	<b>4HX</b>	<b>4HX</b>
$\varnothing d_1$	P	$l_1$	$l_2$	$l_3$	$d_2$	a																																																																																																			
M	mm	mm	mm	mm	mm	mm																																																																																																			
3	0.50	56	12.0		3.5	2.7	3	2.50																																																																																																	
4	0.70	63	14.0		4.5	3.4	3	3.30																																																																																																	
5	0.80	70	15.0		6.0	4.9	3	4.20																																																																																																	
6	1.00	80	15.0	23	6.0	4.9	3	5.00																																																																																																	
8	1.25	90	18.0	29	8.0	6.2	3	6.70																																																																																																	
10	1.50	100	20.0	33	10.0	8.0	3	8.50																																																																																																	
B	C	B	C																																																																																																						
4 x P	2.5 x P	4 x P	2.5 x P																																																																																																						
<b>4HX</b>	<b>4HX</b>	<b>4HX</b>	<b>4HX</b>																																																																																																						
<table border="1"> <thead> <tr> <th>B</th> <th>C</th> <th>B</th> <th>C</th> </tr> <tr> <th>4 x P</th> <th>2.5 x P</th> <th>4 x P</th> <th>2.5 x P</th> </tr> </thead> <tbody> <tr><td><b>6HX</b></td><td><b>6HX</b></td><td><b>6HX</b></td><td><b>6HX</b></td></tr> </tbody> </table>										B	C	B	C	4 x P	2.5 x P	4 x P	2.5 x P	<b>6HX</b>	<b>6HX</b>	<b>6HX</b>	<b>6HX</b>	<table border="1"> <thead> <tr> <th>B</th> <th>C</th> <th>B</th> <th>C</th> </tr> <tr> <th>4 x P</th> <th>2.5 x P</th> <th>4 x P</th> <th>2.5 x P</th> </tr> </thead> <tbody> <tr><td><b>4HX</b></td><td><b>4HX</b></td><td><b>4HX</b></td><td><b>4HX</b></td></tr> </tbody> </table>				B	C	B	C	4 x P	2.5 x P	4 x P	2.5 x P	<b>4HX</b>	<b>4HX</b>	<b>4HX</b>	<b>4HX</b>																																																																				
B	C	B	C																																																																																																						
4 x P	2.5 x P	4 x P	2.5 x P																																																																																																						
<b>6HX</b>	<b>6HX</b>	<b>6HX</b>	<b>6HX</b>																																																																																																						
B	C	B	C																																																																																																						
4 x P	2.5 x P	4 x P	2.5 x P																																																																																																						
<b>4HX</b>	<b>4HX</b>	<b>4HX</b>	<b>4HX</b>																																																																																																						
<table border="1"> <thead> <tr> <th><math>\varnothing d_1</math></th> <th>P</th> <th><math>l_1</math></th> <th><math>l_2</math></th> <th><math>l_3</math></th> <th><math>d_2</math></th> <th>a</th> <th></th> <th></th> <th></th> </tr> <tr> <th>M</th> <th>mm</th> <th>mm</th> <th>mm</th> <th>mm</th> <th>mm</th> <th>mm</th> <th></th> <th></th> <th></th> </tr> </thead> <tbody> <tr><td>3</td><td>0.50</td><td>56</td><td>12.0</td><td></td><td>3.5</td><td>2.7</td><td>3</td><td>2.50</td><td></td></tr> <tr><td>4</td><td>0.70</td><td>63</td><td>14.0</td><td></td><td>4.5</td><td>3.4</td><td>3</td><td>3.30</td><td></td></tr> <tr><td>5</td><td>0.80</td><td>70</td><td>15.0</td><td></td><td>6.0</td><td>4.9</td><td>3</td><td>4.20</td><td></td></tr> <tr><td>6</td><td>1.00</td><td>80</td><td>15.0</td><td>23</td><td>6.0</td><td>4.9</td><td>3</td><td>5.00</td><td></td></tr> <tr><td>8</td><td>1.25</td><td>90</td><td>18.0</td><td>29</td><td>8.0</td><td>6.2</td><td>3</td><td>6.80</td><td></td></tr> <tr><td>10</td><td>1.50</td><td>100</td><td>20.0</td><td>33</td><td>10.0</td><td>8.0</td><td>3</td><td>8.50</td><td></td></tr> </tbody> </table>										$\varnothing d_1$	P	$l_1$	$l_2$	$l_3$	$d_2$	a				M	mm	mm	mm	mm	mm	mm				3	0.50	56	12.0		3.5	2.7	3	2.50		4	0.70	63	14.0		4.5	3.4	3	3.30		5	0.80	70	15.0		6.0	4.9	3	4.20		6	1.00	80	15.0	23	6.0	4.9	3	5.00		8	1.25	90	18.0	29	8.0	6.2	3	6.80		10	1.50	100	20.0	33	10.0	8.0	3	8.50		<table border="1"> <thead> <tr> <th>B</th> <th>C</th> <th>B</th> <th>C</th> </tr> <tr> <th>4 x P</th> <th>2.5 x P</th> <th>4 x P</th> <th>2.5 x P</th> </tr> </thead> <tbody> <tr><td><b>4HX</b></td><td><b>4HX</b></td><td><b>4HX</b></td><td><b>4HX</b></td></tr> </tbody> </table>				B	C	B	C	4 x P	2.5 x P	4 x P	2.5 x P	<b>4HX</b>	<b>4HX</b>	<b>4HX</b>	<b>4HX</b>
$\varnothing d_1$	P	$l_1$	$l_2$	$l_3$	$d_2$	a																																																																																																			
M	mm	mm	mm	mm	mm	mm																																																																																																			
3	0.50	56	12.0		3.5	2.7	3	2.50																																																																																																	
4	0.70	63	14.0		4.5	3.4	3	3.30																																																																																																	
5	0.80	70	15.0		6.0	4.9	3	4.20																																																																																																	
6	1.00	80	15.0	23	6.0	4.9	3	5.00																																																																																																	
8	1.25	90	18.0	29	8.0	6.2	3	6.80																																																																																																	
10	1.50	100	20.0	33	10.0	8.0	3	8.50																																																																																																	
B	C	B	C																																																																																																						
4 x P	2.5 x P	4 x P	2.5 x P																																																																																																						
<b>4HX</b>	<b>4HX</b>	<b>4HX</b>	<b>4HX</b>																																																																																																						
<table border="1"> <thead> <tr> <th><math>\varnothing d_1</math></th> <th>P</th> <th><math>l_1</math></th> <th><math>l_2</math></th> <th><math>l_3</math></th> <th><math>d_2</math></th> <th>a</th> <th></th> <th></th> <th></th> </tr> <tr> <th>M</th> <th>mm</th> <th>mm</th> <th>mm</th> <th>mm</th> <th>mm</th> <th>mm</th> <th></th> <th></th> <th></th> </tr> </thead> <tbody> <tr><td>3</td><td>0.50</td><td>56</td><td>12.0</td><td></td><td>3.5</td><td>2.7</td><td>3</td><td>2.50</td><td></td></tr> <tr><td>4</td><td>0.70</td><td>63</td><td>14.0</td><td></td><td>4.5</td><td>3.4</td><td>3</td><td>3.30</td><td></td></tr> <tr><td>5</td><td>0.80</td><td>70</td><td>15.0</td><td></td><td>6.0</td><td>4.9</td><td>3</td><td>4.20</td><td></td></tr> <tr><td>6</td><td>1.00</td><td>80</td><td>15.0</td><td>23</td><td>6.0</td><td>4.9</td><td>3</td><td>5.00</td><td></td></tr> <tr><td>8</td><td>1.25</td><td>90</td><td>18.0</td><td>29</td><td>8.0</td><td>6.2</td><td>3</td><td>6.80</td><td></td></tr> <tr><td>10</td><td>1.50</td><td>100</td><td>20.0</td><td>33</td><td>10.0</td><td>8.0</td><td>3</td><td>8.50</td><td></td></tr> </tbody> </table>										$\varnothing d_1$	P	$l_1$	$l_2$	$l_3$	$d_2$	a				M	mm	mm	mm	mm	mm	mm				3	0.50	56	12.0		3.5	2.7	3	2.50		4	0.70	63	14.0		4.5	3.4	3	3.30		5	0.80	70	15.0		6.0	4.9	3	4.20		6	1.00	80	15.0	23	6.0	4.9	3	5.00		8	1.25	90	18.0	29	8.0	6.2	3	6.80		10	1.50	100	20.0	33	10.0	8.0	3	8.50		<table border="1"> <thead> <tr> <th>B</th> <th>C</th> <th>B</th> <th>C</th> </tr> <tr> <th>4 x P</th> <th>2.5 x P</th> <th>4 x P</th> <th>2.5 x P</th> </tr> </thead> <tbody> <tr><td><b>6HX</b></td><td><b>6HX</b></td><td><b>6HX</b></td><td><b>6HX</b></td></tr> </tbody> </table>				B	C	B	C	4 x P	2.5 x P	4 x P	2.5 x P	<b>6HX</b>	<b>6HX</b>	<b>6HX</b>	<b>6HX</b>
$\varnothing d_1$	P	$l_1$	$l_2$	$l_3$	$d_2$	a																																																																																																			
M	mm	mm	mm	mm	mm	mm																																																																																																			
3	0.50	56	12.0		3.5	2.7	3	2.50																																																																																																	
4	0.70	63	14.0		4.5	3.4	3	3.30																																																																																																	
5	0.80	70	15.0		6.0	4.9	3	4.20																																																																																																	
6	1.00	80	15.0	23	6.0	4.9	3	5.00																																																																																																	
8	1.25	90	18.0	29	8.0	6.2	3	6.80																																																																																																	
10	1.50	100	20.0	33	10.0	8.0	3	8.50																																																																																																	
B	C	B	C																																																																																																						
4 x P	2.5 x P	4 x P	2.5 x P																																																																																																						
<b>6HX</b>	<b>6HX</b>	<b>6HX</b>	<b>6HX</b>																																																																																																						
<table border="1"> <thead> <tr> <th>B</th> <th>C</th> <th>B</th> <th>C</th> </tr> <tr> <th>4 x P</th> <th>2.5 x P</th> <th>4 x P</th> <th>2.5 x P</th> </tr> </thead> <tbody> <tr><td><b>6HX</b></td><td><b>6HX</b></td><td><b>6HX</b></td><td><b>6HX</b></td></tr> </tbody> </table>										B	C	B	C	4 x P	2.5 x P	4 x P	2.5 x P	<b>6HX</b>	<b>6HX</b>	<b>6HX</b>	<b>6HX</b>	<table border="1"> <thead> <tr> <th>B</th> <th>C</th> <th>B</th> <th>C</th> </tr> <tr> <th>4 x P</th> <th>2.5 x P</th> <th>4 x P</th> <th>2.5 x P</th> </tr> </thead> <tbody> <tr><td><b>6HX</b></td><td><b>6HX</b></td><td><b>6HX</b></td><td><b>6HX</b></td></tr> </tbody> </table>				B	C	B	C	4 x P	2.5 x P	4 x P	2.5 x P	<b>6HX</b>	<b>6HX</b>	<b>6HX</b>	<b>6HX</b>																																																																				
B	C	B	C																																																																																																						
4 x P	2.5 x P	4 x P	2.5 x P																																																																																																						
<b>6HX</b>	<b>6HX</b>	<b>6HX</b>	<b>6HX</b>																																																																																																						
B	C	B	C																																																																																																						
4 x P	2.5 x P	4 x P	2.5 x P																																																																																																						
<b>6HX</b>	<b>6HX</b>	<b>6HX</b>	<b>6HX</b>																																																																																																						

## aero

SA420-4    SA450-3    TL420VS-4    TL451VS-3



**SA420-4**

**SA450-3**

**TL420VS-4**

**TL451VS-3**

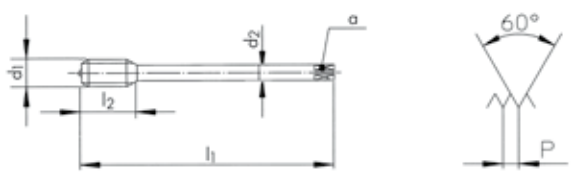
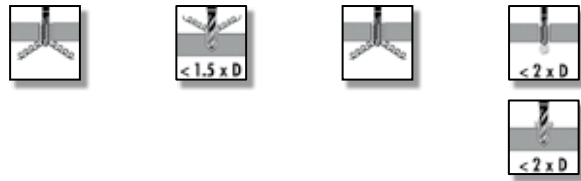

$\varnothing d_1$ M	P mm	$l_1$ mm	$l_2$ mm	$d_2$ mm	$\alpha$ mm		
12	1.75	110	24.0	9.0	7.0	4	10.20
14	2.00	110	28.0	11.0	9.0	4	12.00
16	2.00	110	30.0	12.0	9.0	4	14.00

ID	ID	ID	ID
148096	152189	152192	152195
* 152187			
* 152188	* 152191		152197

$\varnothing d_1$ M	P mm	$l_1$ mm	$l_2$ mm	$d_2$ mm	$\alpha$ mm		
12	1.75	110	24.0	9.0	7.0	4	10.20
14	2.00	110	28.0	11.0	9.0	4	12.00
16	2.00	110	30.0	12.0	9.0	4	14.00

ID	ID	ID	ID
152198	152201	152204	148028
* 152199	* 152202	* 152205	152207
* 152200	152203	* 152206	148029

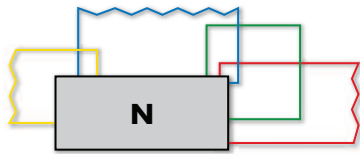
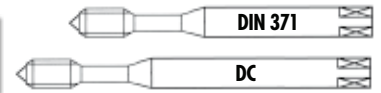

GG350NV-3   GG350TC-3   GG353TC-3   GG550NV-3



**GG350NV-3**

**GG350TC-3**

**GG353TC-3**

**GG550NV-3**

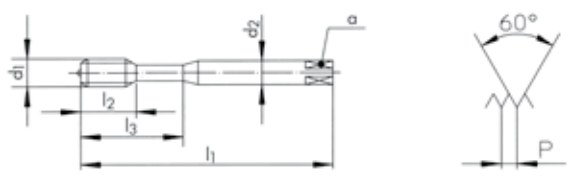

**6HX**   **6HX**   **6HX**   **6HX**

$\varnothing d_1$ M	P mm	$l_1$ mm	$l_2$ mm	$l_3$ mm	$d_2$ mm	$\alpha$ mm		
3	0.50	56	12.0	18	3.5	2.7	3	2.50
4	0.70	63	14.0	21	4.5	3.4	3	3.30
5	0.80	70	15.0	25	6.0	4.9	3	4.20
6	1.00	80	17.0	30	6.0	4.9	3	5.00
8	1.25	90	20.0	35	8.0	6.2	4	6.80
10	1.50	100	22.0	39	10.0	8.0	4	8.50

ID	ID
101172	101178
101173	101179
101174	101180
101175	101181
101076	101182
101171	101177

$\varnothing d_1$ M	P mm	$l_1$ mm	$l_2$ mm	$l_3$ mm	$d_2$ h6 mm	$\alpha$ mm		
5	0.80	70	15.0	25	6.0	4.9	3	4.20
6	1.00	80	17.0	30	6.0	4.9	3	5.00
8	1.25	90	20.0	35	8.0	6.2	4	6.80
10	1.50	100	22.0	39	10.0	8.0	4	8.50

ID
144947
147710
147711
146708

$\varnothing d_1$ M	P mm	$l_1$ mm	$l_2$ mm	$l_3$ mm	$d_2$ mm	$\alpha$ mm		
4	0.70	112	14.0	21	4.5	3.4	3	3.30
5	0.80	125	15.0	25	6.0	4.9	3	4.20
6	1.00	125	17.0	30	6.0	4.9	3	5.00

ID
101196
101197
101198

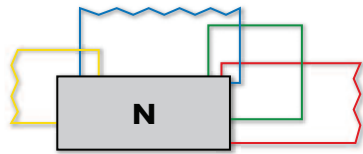
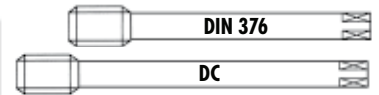

GG450NV-3			
GG450TC-3			
GG453TC-3			
GG650NV-3			

GG450NV-3	GG450TC-3	GG453TC-3	GG650NV-3
-----------	-----------	-----------	-----------

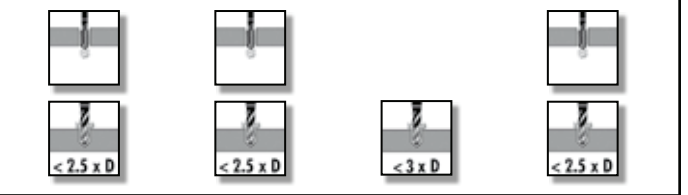
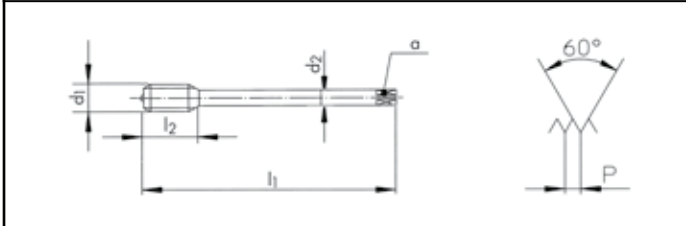

<b>6HX</b>	<b>6HX</b>	<b>6HX</b>	<b>6HX</b>

∅ d <sub>1</sub> M	P mm	l <sub>1</sub> mm	l <sub>2</sub> mm	d <sub>2</sub> mm	a mm		
8	1.25	90	20.0	6.0	4.9	4	6.80
10	1.50	100	22.0	7.0	5.5	4	8.50
12	1.75	110	24.0	9.0	7.0	4	10.20
14	2.00	110	28.0	11.0	9.0	4	12.00
16	2.00	110	30.0	12.0	9.0	4	14.00
20	2.50	140	36.0	16.0	12.0	4	17.50
24	3.00	160	39.0	18.0	14.5	4	21.00

ID	ID
101189	101194
101183	101195
101184	101190
101185	101191
101186	101192
101187	101193
101188	

∅ d <sub>1</sub> M	P mm	l <sub>1</sub> mm	l <sub>2</sub> mm	d <sub>2</sub> h6 mm	a mm		
12	1.75	110	24.0	*10.0	*8.0	4	10.20
16	2.00	110	30.0	12.0	9.0	4	14.00

\* Norme DC / \* DC Norm / \* Norma DC

ID
146707
162796

∅ d <sub>1</sub> M	P mm	l <sub>1</sub> mm	l <sub>2</sub> mm	d <sub>2</sub> mm	a mm		
8	1.25	140	20.0	6.0	4.9	4	6.80
10	1.50	160	22.0	7.0	5.5	4	8.50
12	1.75	180	24.0	9.0	7.0	4	10.20
16	2.00	200	30.0	12.0	9.0	4	14.00
20	2.50	224	36.0	16.0	12.0	4	17.50

ID
101203
101199
101200
101201
101202





Uniquement pour taraudage synchrone  
Nur für Synchroanbearbeitung  
Only for rigid tapping  
Solo per maschiatura sincrona  
Solo para roscado sincronizado

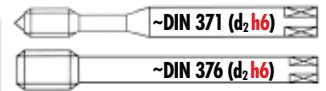

## RTS Rigid Tapping Synchro

RTS320VS-4



VS

11	12	13	14
15	21	22	31
32	61	63	72
73	74		

RTS420VS-4



VS

11	12	13	14
15	21	22	31
32	61	63	72
73	74		

RTS323VS-4



VS

11	12	13	14
15	21	22	31
32	61	63	72
73	74		

RTS423VS-4



VS

11	12	13	14
15	21	22	31
32	61	63	72
73	74		

RTS320VS-4

RTS420VS-4

RTS323VS-4

RTS423VS-4

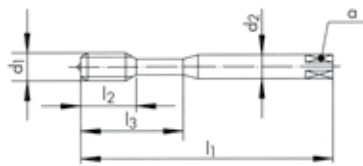

$\varnothing d_1$ M	P mm	$l_1$ mm	$l_2$ mm	$l_3$ mm	$d_2, h_6$ mm	$a$ mm		
*2	0.40	45	8.0		2.8(h9)	2.1	2	1.60
2.5	0.45	50	10.0		2.8(h9)	2.1	3	2.05
3	0.50	56	5.5	18	3.5(h9)	2.7	3	2.50
4	0.70	63	7.5	21	4.5(h9)	3.4	3	3.30
5	0.80	70	9.0	25	6.0	4.9	3	4.20
6	1.00	80	11.0	30	6.0	4.9	3	5.00
8	1.25	90	12.5	35	8.0	6.2	3	6.80
10	1.50	100	14.0	39	10.0	8.0	3	8.50
12	1.75	110	14.0		*10.0	*8.0	3	10.20
14	2.00	110	14.0		*12.0	*9.0	3	12.00
16	2.00	110	18.0		12.0	9.0	3	14.00
20	2.50	140	24.0		16.0	12.0	4	17.50
24	3.00	160	27.0		16.0	12.0	4	21.00

ID

ID

ID

ID

143532

143534

150601

150603

150605

150606

150610

150611

150620

150621

150635

150636

151863

151864

162535

150670

150671

150679

162787

\* Norme DC / \* DC Norm / \* Norma DC

\* RTS320VS-3



sur demande  
auf Anfrage  
on request  
su richiesta  
sobre pedido



Uniquement pour taraudage synchro  
Nur für Synchrobearbeitung  
Only for rigid tapping  
Solo per maschiatura sincrona  
Solo para roscado sincronizado

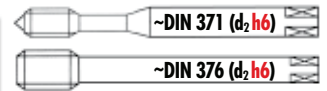

## RTS Rigid Tapping Synchro

RTS362VS-3



RTS462VS-3



RTS365VS-3

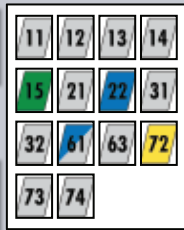

RTS465VS-3



RTS362VS-3



RTS462VS-3



RTS365VS-3



RTS465VS-3

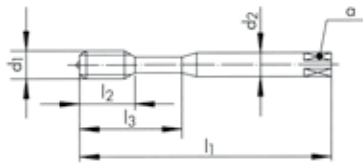

∅ d <sub>1</sub> M	P mm	l <sub>1</sub> mm	l <sub>2</sub> mm	l <sub>3</sub> mm	d <sub>2</sub> h6 mm	a mm		
*2	0.40	45	7.0		2.8 (h9)	2.1	3	1.60
*2.5	0.45	50	9.0		2.8 (h9)	2.1	3	2.05
3	0.50	56	5.5	18	3.5 (h9)	2.7	3	2.50
4	0.70	63	7.5	21	4.5 (h9)	3.4	3	3.30
5	0.80	70	9.0	25	6.0	4.9	3	4.20
6	1.00	80	11.0	30	6.0	4.9	3	5.00
8	1.25	90	12.5	35	8.0	6.2	3	6.80
10	1.50	100	14.0	39	10.0	8.0	3	8.50
12	1.75	110	14.0		*10.0	*8.0	3	10.20
14	2.00	110	14.0		*12.0	*9.0	3	12.00
16	2.00	110	18.0		12.0	9.0	3	14.00
20	2.50	140	24.0		16.0	12.0	4	17.50
24	3.00	160	27.0		16.0	12.0	4	21.00

ID

ID

ID

ID

143536

143538

150602

150604

150607

150612

150622

150637

160477

160478

150608

150613

150623

150638

151865

151870

150672

150681

151873

151866

150663

150673

150682

150690

\* Norme DC / \* DC Norm / \* Norma DC

\* RTS360VS-3



sur demande  
auf Anfrage  
on request  
su richiesta  
sobre pedido



Uniquement pour taraudage synchrone  
Nur für Synchroanbearbeitung  
Only for rigid tapping  
Solo per maschiatura sincrona  
Solo para roscado sincronizado



## RTS Rigid Tapping Synchro

RTS362VS-5



VS



RTS365VS-5



VS

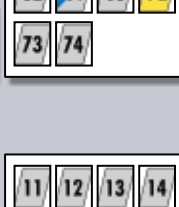

RTS362VS-3



VS

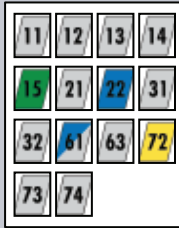

RTS362VS-5

RTS365VS-5

RTS362VS-3

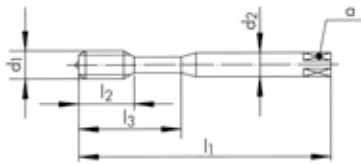

∅ d <sub>1</sub> M	P mm	l <sub>1</sub> mm	l <sub>2</sub> mm	l <sub>3</sub> mm	d <sub>2</sub> h6 mm	a mm		
3	0.50	56	5.5	18	3.5 (h9)	2.7	3	2.50
4	0.70	63	7.5	21	4.5 (h9)	3.4	3	3.30
5	0.80	70	9.0	25	6.0	4.9	3	4.20
6	1.00	80	11.0	30	6.0	4.9	3	5.00
8	1.25	90	12.5	35	8.0	6.2	3	6.80
10	1.50	100	14.0	39	10.0	8.0	3	8.50

ID

ID

157648

157650

157652

162791

158074

151803

158076

157821

153286

157823

∅ d <sub>1</sub> M	P mm	l <sub>1</sub> mm	l <sub>2</sub> mm	l <sub>3</sub> mm	d <sub>2</sub> h6 mm	a mm			6H
3	0.50	56	5.5	18	3.5 (h9)	2.7	3	2.50	ID 6H + mm
4	0.70	63	7.5	21	4.5 (h9)	3.4	3	3.35	162797 0.020
5	0.80	70	9.0	25	6.0	4.9	3	4.25	162798 0.022
6	1.00	80	11.0	30	6.0	4.9	3	5.00	162799 0.024
8	1.25	90	12.5	35	8.0	6.2	3	6.80	162800 0.026
10	1.50	100	14.0	39	10.0	8.0	3	8.50	162801 0.028
									162802 0.032



sur demande  
auf Anfrage  
on request  
su richiesta  
sobre pedido



Uniquement pour taraudage synchrone  
Nur für Synchrobearbeitung  
Only for rigid tapping  
Solo per maschiatura sincrona  
Solo para roscado sincronizado

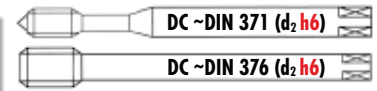

## RTS Rigid Tapping Synchro

**RTS523VS-4** **VS**

11	12	13	14
15	21	22	31
32	61	63	72
73	74		

**RTS623VS-4** **VS**

11	12	13	14
15	21	22	31
32	61	63	72
73	74		

**RTS565VS-3** **VS**

11	12	13	14
15	21	22	31
32	61	63	72
73	74		

**RTS665VS-3** **VS**

11	12	13	14
15	21	22	31
32	61	63	72
73	74		

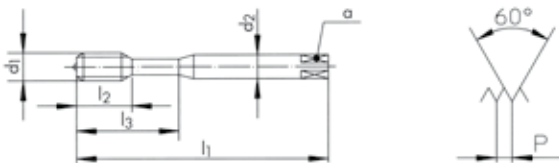

RTS523VS-4	RTS623VS-4	RTS565VS-3	RTS665VS-3
------------	------------	------------	------------

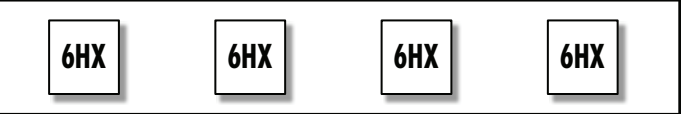

∅ d <sub>1</sub> M	P mm	l <sub>1</sub> mm	l <sub>2</sub> mm	l <sub>3</sub> mm	d <sub>2</sub> h6 mm	a mm		
5	0.80	125	9.0	25	6.0	4.9	3	4.20
6	1.00	125	11.0	30	6.0	4.9	3	5.00
8	1.25	140	12.5	35	8.0	6.2	3	6.80
10	1.50	160	14.0	39	10.0	8.0	3	8.50
12	1.75	180	14.0		*10.0	*8.0	3	10.20
16	2.00	200	18.0		12.0	9.0	3	14.00

ID	ID
161038	
161041	
161044	
161047	
	161050
	161053

\* Norme DC / \* DC Norm / \* Norma DC

∅ d <sub>1</sub> M	P mm	l <sub>1</sub> mm	l <sub>2</sub> mm	l <sub>3</sub> mm	d <sub>2</sub> h6 mm	a mm		
6	1.00	125	11.0	30	6.0	4.9	3	5.00
8	1.25	140	12.5	35	8.0	6.2	3	6.80
10	1.50	160	14.0	39	10.0	8.0	3	8.50
12	1.75	180	14.0		*10.0	*8.0	3	10.20
16	2.00	200	18.0		12.0	9.0	3	14.00

ID	ID
	150614
	150624
	150639
	151867
	150674

\* Norme DC / \* DC Norm / \* Norma DC

sur demande  
auf Anfrage  
on request  
su richiesta  
sobre pedido  
≥ ∅ 6 mm

## K

K313TC-3

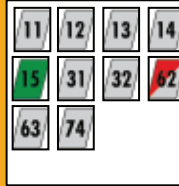

K413TC-3

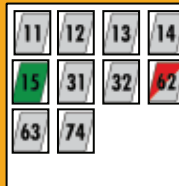

K313TC-3

K413TC-3



6HX

6HX

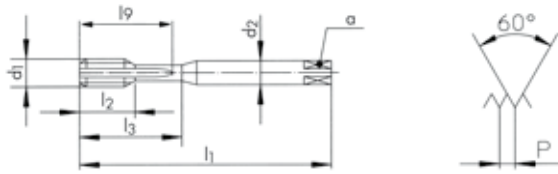

$\varnothing d_1$ M	P mm	$l_1$ mm	$l_2$ mm	$l_3$ mm	$l_9$ mm	$d_2$ mm	a mm		
6	1.00	80	17.0	30	28.0	6.0	4.9	3	5.00
8	1.25	90	20.0	35	33.0	8.0	6.2	3	6.80
10	1.50	100	22.0	39	37.0	10.0	8.0	3	8.50
12	1.75	110	24.0	42.0	42.0	9.0	7.0	3	10.20
14	2.00	110	28.0	49.0	49.0	11.0	9.0	3	12.00
16	2.00	110	30.0	56.0	56.0	12.0	9.0	4	14.00
20	2.50	140	36.0	70.0	70.0	16.0	12.0	5	17.50
24	3.00	160	39.0	84.0	84.0	18.0	14.5	5	21.00

ID

ID

170766

170769

170772

165838









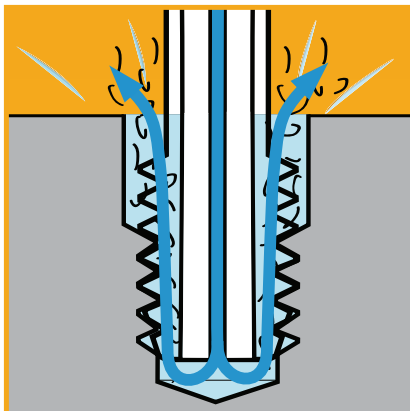









170778



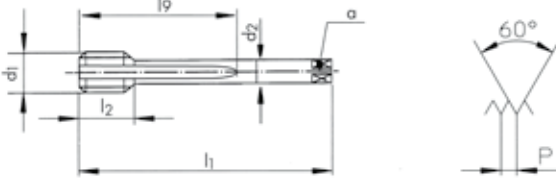

170783

170786

170775



<b>K</b>									K613TC-3	K613VS-3		
<p><b>K613TC-3</b></p>      												
<p><b>K613VS-3</b></p>      										<b>NEW</b>		
												
									<b>6HX</b>	<b>6HX</b>		
$\varnothing d_1$ M	P mm	$l_1$ mm	$l_2$ mm	$l_9$ mm	$d_2$ mm	$\alpha$ mm			<b>ID</b>	<b>ID</b>		
6	1.00	110	17.0	30	4.5	3.4	3	5.00	170646	172699		
8	1.25	110	20.0	40	6.0	4.9	3	6.80	170649	172700		
10	1.50	125	22.0	50	7.0	5.5	3	8.50	170652	172701		
12	1.75	140	24.0	60	9.0	7.0	3	10.20	167982	172702		
14	2.00	140	28.0	70	11.0	9.0	3	12.00	167983			
16	2.00	160	30.0	80	12.0	9.0	4	14.00	167984	170573		
20	2.50	180	36.0	100	16.0	12.0	5	17.50	167985	170576		
24	3.00	200	39.0	120	18.0	14.5	5	21.00	167986	172704		
27	3.00	225	42.0	135	20.0	16.0	5	24.00	167987			
30	3.50	250	45.0	150	22.0	18.0	5	26.50	165542			
33	3.50	280	48.0	165	25.0	20.0	5	29.50	167988			
36	4.00	300	51.0	180	28.0	22.0	6	32.00	167989			
39	4.00	300	55.0	195	32.0	24.0	6	35.00	167990			
42	4.50	355	55.0	210	32.0	24.0	6	37.50	167999			

Vc (m/min)				
	M6 - M10	M12 - M16	M20 - M30	M33 - M42
	32	28	22	18
	30	25	20	15
	24	20	16	12
	15	12	8	6
	35	30	25	20

## FS FORMING

FS380VS-5



FS380VS-3



FS380VS-5

FS380VS-3

FS380VS-3

FS380VS-3

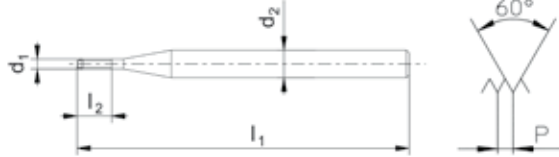

$\varnothing d_1$ M	P mm	$l_1$ mm	$l_2$ mm	$d_2$ mm	$a$ mm	4HX Tol. 6HX	ID	ID	ID	ID	6H + mm
1	0.25	40	3.0	2.5		0.88 +0.02	157171	173452			
1.2	0.25	40	3.6	2.5		1.08 +0.02	157172	173455			
1.4	0.30	40	4.2	2.5		1.25 +0.02	157173	173458			
1.6	0.35	40	4.8	2.5		1.45 +0.02	157174	169779			
1.7	0.35	40	5.1	2.5		1.55 +0.02		169782			
1.8	0.35	40	5.4	2.5		1.65 +0.02	157175	169785			
2	0.40	45	8.0	2.8	2.1	1.80 +0.02			157176		157180 0.019
2.5	0.45	50	10.0	2.8	2.1	2.30 +0.02			157178		157181 0.020
2.6	0.45	50	10.0	2.8	2.1	2.40 +0.02			157179		

≤ M1.5 4HX

## FS FORMING

FS380DL-5



11	12	13	14
21	22	23	24
41	51	61	63
71	72	73	

FS380DL-3



11	12	13	14
21	22	23	24
41	51	61	63
71	72	73	

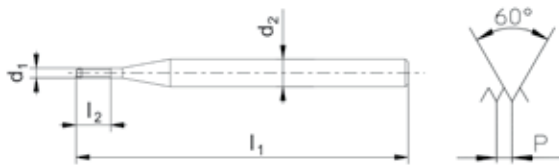

FS380DL-5    FS380DL-3    FS380DL-3    FS380DL-3



NEW    NEW    NEW    NEW



6HX    6HX    6HX    6GX

$\varnothing d_1$ M	P mm	$l_1$ mm	$l_2$ mm	$d_2$ mm	$\alpha$ mm	4HX Tol. 6HX
1	0.25	40	3.0	2.5		0.88 +0.02
1.2	0.25	40	3.6	2.5		1.08 +0.02
1.4	0.30	40	4.2	2.5		1.25 +0.02
1.6	0.35	40	4.8	2.5		1.45 +0.02
1.7	0.35	40	5.1	2.5		1.55 +0.02
1.8	0.35	40	5.4	2.5		1.65 +0.02
2	0.40	45	8.0	2.8	2.1	1.80 +0.02
2.5	0.45	50	10.0	2.8	2.1	2.30 +0.02
2.6	0.45	50	10.0	2.8	2.1	2.40 +0.02

ID	ID	ID	ID	6H + mm
172839	173461			
172840	173464			
172841	173467			
170585	170916			
	172843			
172842	172844			
		158814		172849 0.019
		172845		173246 0.020
		172846		

≤ M1.5 4HX



## FPS FORMING

FPS380CN-3



CrN



FPS381CN-3



CrN



FPS380VS-3



VS



FPS381VS-3



VS

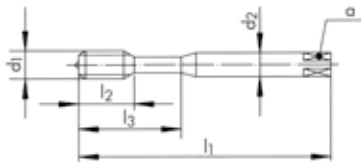

FPS380CN-3

FPS381CN-3

FPS380VS-3

FPS381VS-3



6HX

6HX

6HX

6HX

$\varnothing d_1$ M	P mm	$l_1$ mm	$l_2$ mm	$l_3$ mm	$d_2$ mm	$a$ mm	6HX Tol. → ←
3	0.50	56	12.0	18	3.5	2.7	2.80 + 0.03
3.5	0.60	56	13.0	20	4.0	3.0	3.25 + 0.03
4	0.70	63	14.0	21	4.5	3.4	3.70 + 0.03
5	0.80	70	15.0	25	6.0	4.9	4.65 + 0.03
6	1.00	80	17.0	30	6.0	4.9	5.55 + 0.05
8	1.25	90	20.0	35	8.0	6.2	7.40 + 0.05
10	1.50	100	22.0	39	10.0	8.0	9.30 + 0.05

ID

ID

ID

ID

166613

166615

166614

166616

166619

166621

166620

166622

166626

166628

166627

166629

166634

166636

166635

166637

166643

166645

166644

166646

166653

166655

166654

166656

166663

166665

166664

166666

6GX

6GX

$\varnothing d_1$ M	P mm	$l_1$ mm	$l_2$ mm	$l_3$ mm	$d_2$ mm	$a$ mm	6HX Tol. → ←
3	0.50	56	12.0	18	3.5	2.7	2.80 + 0.03
3.5	0.60	56	13.0	20	4.0	3.0	3.25 + 0.03
4	0.70	63	14.0	21	4.5	3.4	3.70 + 0.03
5	0.80	70	15.0	25	6.0	4.9	4.65 + 0.03
6	1.00	80	17.0	30	6.0	4.9	5.55 + 0.05
8	1.25	90	20.0	35	8.0	6.2	7.40 + 0.05
10	1.50	100	22.0	39	10.0	8.0	9.30 + 0.05

ID 6H  
+ mm

ID 6H  
+ mm

166697 0.020 166617 0.020

166687 0.021 166623 0.021

166688 0.022 166630 0.022

166689 0.024 166638 0.024

166686 0.026 166647 0.026

166740 0.028 166657 0.028

166739 0.032 166667 0.032

## FPS FORMING

FPS481VS-3



FPS581VS-3



FPS681VS-3



FPS481VS-3

FPS581VS-3

FPS681VS-3



6HX

6HX

6HX

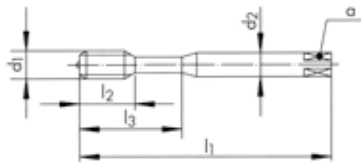

$\varnothing d_1$ M	P mm	$l_1$ mm	$l_2$ mm	$d_2$ mm	$a$ mm	6HX Tol. → ←	ID
12	1.75	110	24.0	9.0	7.0	11.20 + 0.05	166673
14	2.00	110	28.0	11.0	9.0	13.10 + 0.05	166678
16	2.00	110	30.0	12.0	9.0	15.10 + 0.05	166683
20	2.50	140	36.0	16.0	12.0	18.85 + 0.05	168713

$\varnothing d_1$ M	P mm	$l_1$ mm	$l_2$ mm	$l_3$ mm	$d_2$ mm	$a$ mm	6HX Tol. → ←	ID	ID
3	0.50	100	12.0	18	3.5	2.7	2.80 + 0.03	172824	
4	0.70	125	14.0	21	4.5	3.4	3.70 + 0.03	172826	
5	0.80	140	15.0	25	6.0	4.9	4.65 + 0.03	172828	
6	1.00	160	17.0	30	6.0	4.9	5.55 + 0.05	172830	
8	1.25	180	20.0	35	8.0	6.2	7.40 + 0.05	172832	
10	1.50	200	22.0	39	10.0	8.0	9.30 + 0.05	172834	
12	1.75	224	24.0		9.0	7.0	11.20 + 0.05		172836

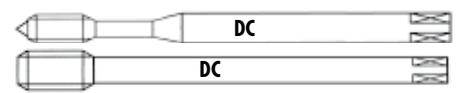
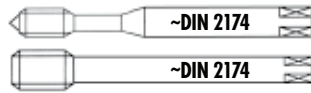

## FPS FORMING

FPS384VS-3		<b>VS</b>	<table border="1"> <tr><td>11</td><td>12</td><td>13</td><td>14</td></tr> <tr><td>15</td><td>21</td><td>24</td><td>63</td></tr> </table>	11	12	13	14	15	21	24	63
11	12	13	14								
15	21	24	63								
FPS484VS-3		<b>VS</b>	<table border="1"> <tr><td>11</td><td>12</td><td>13</td><td>14</td></tr> <tr><td>15</td><td>21</td><td>24</td><td>63</td></tr> </table>	11	12	13	14	15	21	24	63
11	12	13	14								
15	21	24	63								
FPS584VS-3		<b>EL VS</b>	<table border="1"> <tr><td>11</td><td>12</td><td>13</td><td>14</td></tr> <tr><td>15</td><td>21</td><td>24</td><td>63</td></tr> </table>	11	12	13	14	15	21	24	63
11	12	13	14								
15	21	24	63								
FPS684VS-3		<b>EL VS</b>	<table border="1"> <tr><td>11</td><td>12</td><td>13</td><td>14</td></tr> <tr><td>15</td><td>21</td><td>24</td><td>63</td></tr> </table>	11	12	13	14	15	21	24	63
11	12	13	14								
15	21	24	63								

FPS384VS-3	FPS484VS-3	FPS584VS-3	FPS684VS-3
------------	------------	------------	------------

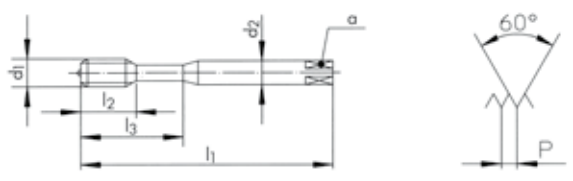
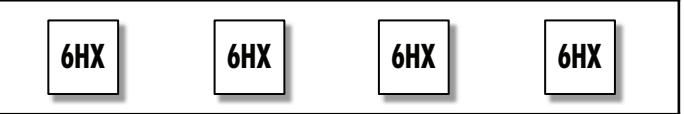
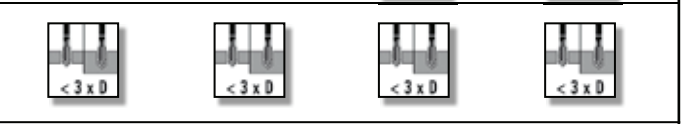

$\varnothing d_1$ M	P mm	$l_1$ mm	$l_2$ mm	$l_3$ mm	$d_2$ mm	$\alpha$ mm	6HX → ←	Tol.
3	0.50	56	12.0	18	3.5	2.7	2.80	+ 0.03
4	0.70	63	14.0	21	4.5	3.4	3.70	+ 0.03
5	0.80	70	15.0	25	6.0	4.9	4.65	+ 0.03
6	1.00	80	17.0	30	6.0	4.9	5.55	+ 0.05
8	1.25	90	20.0	35	8.0	6.2	7.40	+ 0.05
10	1.50	100	22.0	39	10.0	8.0	9.30	+ 0.05
12	1.75	110	24.0		9.0	7.0	11.20	+ 0.05
14	2.00	110	28.0		11.0	9.0	13.10	+ 0.05
16	2.00	110	30.0		12.0	9.0	15.10	+ 0.05

ID	ID
166737	
166738	
166640	
166650	
166660	
166670	
	166675
	166680
	166685

$\varnothing d_1$ M	P mm	$l_1$ mm	$l_2$ mm	$l_3$ mm	$d_2$ mm	$\alpha$ mm	6HX → ←	Tol.
3	0.50	100	12.0	18	3.5	2.7	2.80	+ 0.03
4	0.70	125	14.0	21	4.5	3.4	3.70	+ 0.03
5	0.80	140	15.0	25	6.0	4.9	4.65	+ 0.03
6	1.00	160	17.0	30	6.0	4.9	5.55	+ 0.05
8	1.25	180	20.0	35	8.0	6.2	7.40	+ 0.05
10	1.50	200	22.0	39	10.0	8.0	9.30	+ 0.05
12	1.75	224	24.0		9.0	7.0	11.20	+ 0.05

ID	ID
	172763
	172766
	172769
	172772
	172775
	172778
	172781

## FAS FORMING

FAS380VS-3



VS



FAS381VS-3



VS

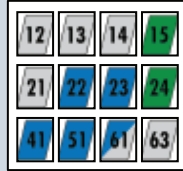

FAS481VS-3



VS

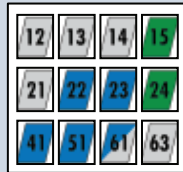

FAS380VS-3



FAS381VS-3



FAS481VS-3



6HX

6HX

6HX

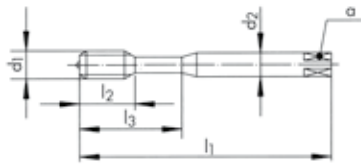

∅ d <sub>1</sub> M	P mm	l <sub>1</sub> mm	l <sub>2</sub> mm	l <sub>3</sub> mm	d <sub>2</sub> mm	a mm	6HX Tol. → ←
3	0.50	56	12.0	18	3.5	2.7	2.80 + 0.03
3.5	0.60	56	13.0	20	4.0	3.0	3.25 + 0.03
4	0.70	63	14.0	21	4.5	3.4	3.70 + 0.03
5	0.80	70	15.0	25	6.0	4.9	4.65 + 0.03
6	1.00	80	17.0	30	6.0	4.9	5.55 + 0.05
8	1.25	90	20.0	35	8.0	6.2	7.40 + 0.05
10	1.50	100	22.0	39	10.0	8.0	9.30 + 0.05
12	1.75	110	24.0		9.0	7.0	11.20 + 0.05
14	2.00	110	28.0		11.0	9.0	13.10 + 0.05
16	2.00	110	30.0		12.0	9.0	15.10 + 0.05
20	2.50	140	36.0		16.0	12.0	18.85 + 0.05

ID

ID

ID

170603	166612	
170605	166618	
170607	166624	
170609	166632	
170611	166641	
170616	166651	
170618	166661	166671
		166676
		166681
		168711

6GX

6GX

∅ d <sub>1</sub> M	P mm	l <sub>1</sub> mm	l <sub>2</sub> mm	l <sub>3</sub> mm	d <sub>2</sub> mm	a mm	6HX Tol. → ←
3	0.50	56	12.0	18	3.5	2.7	2.80 + 0.03
3.5	0.60	56	13.0	20	4.0	3.0	3.25 + 0.03
4	0.70	63	14.0	21	4.5	3.4	3.70 + 0.03
5	0.80	70	15.0	25	6.0	4.9	4.65 + 0.03
6	1.00	80	17.0	30	6.0	4.9	5.55 + 0.05
8	1.25	90	20.0	35	8.0	6.2	7.40 + 0.05
10	1.50	100	22.0	39	10.0	8.0	9.30 + 0.05
12	1.75	110	24.0		9.0	7.0	11.20 + 0.05
14	2.00	110	28.0		11.0	9.0	13.10 + 0.05
16	2.00	110	30.0		12.0	9.0	15.10 + 0.05

ID 6H + mm

ID 6H + mm

166703	0.020	
* 166704	0.021	
166705	0.022	
166706	0.024	
166707	0.026	
166708	0.028	
166709	0.032	
		166710 0.034
		166711 0.038
		166712 0.038

## FAS FORMING

FAS384VS-3



VS

12	13	14	15
21	22	23	24
41	51	61	63

FAS484VS-3



VS

12	13	14	15
21	22	23	24
41	51	61	63

FAS384VS-3

FAS484VS-3

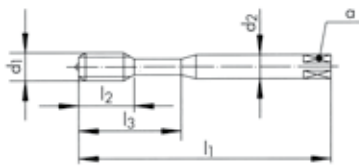

6HX

6HX

$\varnothing d_1$ M	P mm	$l_1$ mm	$l_2$ mm	$l_3$ mm	$d_2$ mm	$a$ mm	6HX Tol. → ←	ID	ID
3	0.50	56	12.0	18	3.5	2.7	2.80 + 0.03	166741	
4	0.70	63	14.0	21	4.5	3.4	3.70 + 0.03	166742	
5	0.80	70	15.0	25	6.0	4.9	4.65 + 0.03	166690	
6	1.00	80	17.0	30	6.0	4.9	5.55 + 0.05	166691	
8	1.25	90	20.0	35	8.0	6.2	7.40 + 0.05	166692	
10	1.50	100	22.0	39	10.0	8.0	9.30 + 0.05	166693	
12	1.75	110	24.0		9.0	7.0	11.20 + 0.05		166694
14	2.00	110	28.0		11.0	9.0	13.10 + 0.05		* 166695
16	2.00	110	30.0		12.0	9.0	15.10 + 0.05		166696

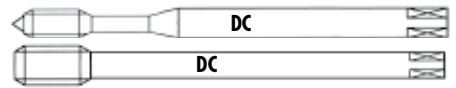

## FAS FORMING

**FAS581VS-3** **EL VS**

**FAS681VS-3** **EL VS**

**FAS584VS-3** **EL VS**

**FAS684VS-3** **EL VS**



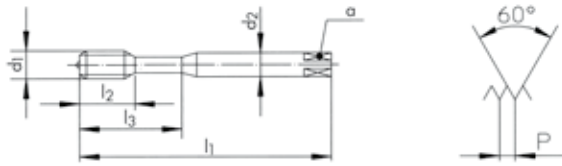
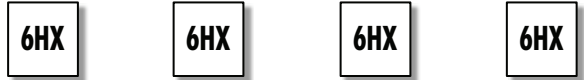





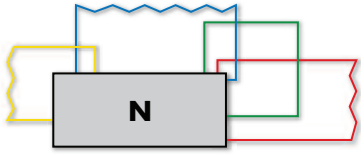

FAS581VS-3	FAS681VS-3	FAS584VS-3	FAS684VS-3
------------	------------	------------	------------

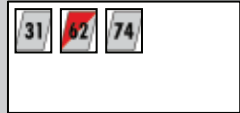

$\varnothing d_1$ M	P mm	$l_1$ mm	$l_2$ mm	$l_3$ mm	$d_2$ mm	$\alpha$ mm	6HX Tol. → ←
3	0.50	100	12.0	18	3.5	2.7	2.80 + 0.03
4	0.70	125	14.0	21	4.5	3.4	3.70 + 0.03
5	0.80	140	15.0	25	6.0	4.9	4.65 + 0.03
6	1.00	160	17.0	30	6.0	4.9	5.55 + 0.05
8	1.25	180	20.0	35	8.0	6.2	7.40 + 0.05
10	1.50	200	22.0	39	10.0	8.0	9.30 + 0.05
12	1.75	224	24.0		9.0	7.0	11.20 + 0.05

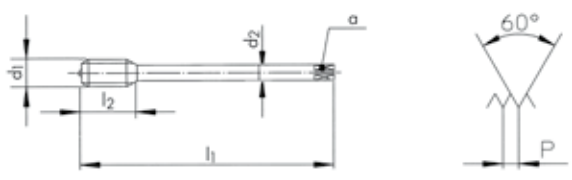
ID	ID	ID	ID
172784		172805	
172787		172808	
172790		172811	
172793		172814	
172796		172817	
172799		172820	
	172802		172822

										N1110-1	N1110-2	N1110-3	N1110-S
N1110-1													
N1110-2													
N1110-3	<div style="float: right; border: 1px solid black; padding: 2px;"> <span style="border: 1px solid black; padding: 1px;">31</span> <span style="border: 1px solid black; padding: 1px; color: red;">62</span> <span style="border: 1px solid black; padding: 1px;">74</span> </div>												
N1110-S													
												ISO 2 6H	ISO 2 6H
Ø d <sub>1</sub> M	P mm	l <sub>1</sub> mm	l <sub>2</sub> mm	l <sub>3</sub> mm	d <sub>2</sub> mm	a mm			ID	ID	ID	ID	
1	0.25	40	5.5		2.50	2.10	3	0.75	102744	102844	102917	111015	
1.2	0.25	40	5.5		2.50	2.10	3	0.95	102746	102846	102919	111017	
1.4	0.30	40	7.0		2.50	2.10	3	1.10	102747	102847	102920	111018	
1.6	0.35	40	8.0		2.50	2.10	3	1.25	102749	102849	102922	111020	
1.7	0.35	40	8.0		2.50	2.10	3	1.35	102750	102850	102923	111021	
1.8	0.35	40	8.0		2.50	2.10	3	1.45	102751	102851	102924	111022	
2	0.40	45	8.0		2.80	2.10	3	1.60	102759	102854	102934	111028	
2.2	0.45	45	9.5		2.80	2.10	3	1.75	102761	102856	102937	111030	
2.5	0.45	45	9.5		2.80	2.10	3	2.05	102763	102858	102941	111032	
2.6	0.45	45	9.5		2.80	2.10	3	2.15	102765	102860	102944	111034	
3	0.50	48	11.0	18	3.15	2.50	3	2.50	102766	102861	102947	111036	
3.5	0.60	50	13.0	20	3.55	2.80	3	2.90	102769	102864	102950	111038	
4	0.70	53	13.0	21	4.00	3.15	3	3.30	102771	102866	102956	111042	
4.5	0.75	53	13.0	21	4.50	3.55	3	3.75	102775	102869	102959	111044	
5	0.80	58	16.0	25	5.00	4.00	3	4.20	102776	102870	102965	111047	
6	1.00	66	19.0	30	6.30	5.00	3	5.00	102781	102874	102973	111053	
7	1.00	66	19.0	30	7.10	5.60	3	6.00	102786	102876	102978	111055	
8	1.25	72	22.0	35	8.00	6.30	3	6.80	102788	102878	102986	111059	
9	1.25	72	22.0	36	9.00	7.10	3	7.80	102792	102880	102991	111061	
10	1.50	80	24.0	39	10.00	8.00	3	8.50	102752	102852	102931	111026	
										<div style="border: 1px solid black; padding: 5px; display: inline-block;">             ≤ M1.5    ISO 1 4H           </div>			

								N1210-1	N1210-2	N1210-3	N1210-S
											
N1210-1											
N1210-2											
N1210-3											
N1210-S											
											
										ISO 2 6H	ISO 2 6H
∅ d <sub>1</sub> M	P mm	l <sub>1</sub> mm	l <sub>2</sub> mm	d <sub>2</sub> mm	α mm			ID	ID	ID	ID
11	1.50	85	22.0	8.0	6.3	3	9.50	103302	103427	103489	111168
12	1.75	89	24.0	9.0	7.1	3	10.20	103303	103428	103499	111173
14	2.00	95	24.0	11.2	9.0	3	12.00	103310	103430	103510	111179
16	2.00	102	32.0	12.5	10.0	3	14.00	103319	103432	103522	111185
18	2.50	112	30.0	14.0	11.2	3	15.50	103324	103434	103534	111191
20	2.50	112	37.0	14.0	11.2	3	17.50	103330	103436	103543	111196
22	2.50	115	32.0	16.0	12.5	3	19.50	103337	103438	103550	125567
24	3.00	130	45.0	18.0	14.0	4	21.00	103341	103440	103557	111204
27	3.00	135	45.0	20.0	16.0	4	24.00	103347	103442	103568	111211
30	3.50	138	48.0	20.0	16.0	4	26.50	103353	103444	103579	111216
33	3.50	151	51.0	22.4	18.0	4	29.50	103357	103446	103581	111218
36	4.00	162	57.0	25.0	20.0	4	32.00	103359	103448	103583	111220



										N1120-4	N1220-4	N1160-3	N1260-3
N1120-4													
N1220-4												<b>NEW</b>	<b>NEW</b>
N1160-3													
N1260-3													
$\varnothing d_1$	P	$l_1$	$l_2$	$l_3$	$d_2$	$a$				ID	ID		
M	mm	mm	mm	mm	mm	mm							
3	0.50	48	11.0	18	3.15	2.50	3	2.50		103068			
4	0.70	53	13.0	21	4.00	3.15	3	3.30		103075			
4.5	0.75	53	13.0	21	4.50	3.55	3	3.75		* 103078			
5	0.80	58	16.0	25	5.00	4.00	3	4.20		103082			
6	1.00	66	19.0	30	6.30	5.00	3	5.00		103090			
8	1.25	72	22.0	35	8.00	6.30	3	6.80		103102			
10	1.50	80	24.0	39	10.00	8.00	3	8.50		103060			
11	1.50	85	22.0		8.00	6.30	3	9.50			* 103661		
12	1.75	89	24.0		9.00	7.10	3	10.20			103670		
14	2.00	95	24.0		11.20	9.00	3	12.00			103680		
16	2.00	102	32.0		12.50	10.00	3	14.00			103690		
$\varnothing d_1$	P	$l_1$	$l_2$	$l_3$	$d_2$	$a$				ID	ID		
M	mm	mm	mm	mm	mm	mm							
3	0.50	48	5.5	18	3.15	2.50	3	2.50			103177		
4	0.70	53	7.5	21	4.00	3.15	3	3.30			103178		
5	0.80	58	9.0	25	5.00	4.00	3	4.20			103179		
6	1.00	66	11.0	30	6.30	5.00	3	5.00			103180		
8	1.25	72	12.5	35	8.00	6.30	3	6.80			103181		
10	1.50	80	14.0	39	10.00	8.00	3	8.50			103174		
12	1.75	89	14.0		9.00	7.10	3	10.20				103781	
16	2.00	102	18.0		12.50	10.00	3	14.00				103782	



**285**

