

**CHIA-MO**

WWW.CHIAMO.IT

I T A L Y

# PORTA MASCHI PORTA FILIERE

TAP AND DIE HOLDERS



# PORTA MASCHI PORTA FILIERE TAP AND DIE HOLDERS

I porta maschi e filiere vengono impiegati su macchine da produzione quali torni monomandrino, plurimandrino e cnc, centri di lavoro, trapani e transfer. Vengono usati per tutte le operazioni di filettatura e migliorano notevolmente la durata dell'utensile evitando frequenti rotture. La parte dell'attrezzatura sulla quale viene montato il maschio/filiera può scorrere assialmente grazie a delle molle interne e inoltre ha un leggero gioco radiale rispetto alla parte che viene montata in macchina. Il gioco assiale dato dalle molle interne è fondamentale nella fase di lavorazione in cui il senso di rotazione del maschio/filiera viene invertito. Inoltre l'oscillazione assiali e radiale compensano gli errori di allineamento tra il mandrino della macchina ed il pezzo in lavorazione per ottenere una lavorazione di alta qualità.

## Descrizione e specifiche

I mandrini porta maschi e filiere sono costruiti con acciaio certificato altamente legato, sono temprati e completamente rettificati. Tutto il ciclo produttivo viene svolto nel nostro stabilimento in Italia con macchine utensili di alta precisione ed è rigorosamente controllato. Grazie all'ampia disponibilità di magazzino possiamo generalmente spedire il materiale il giorno stesso della ricezione dell'ordine.

## Maggiori informazioni

Possono essere forniti con attacco cilindrico metrico e in pollici e attacco Vdi.

## Prodotti

Porta maschi e filiera con compressione e estrazione  
- Porta filiere ad estrazione - Porta maschi doppi ad estrazione - Porta maschi con attacco VDI DIN 69880  
- Pinze ER porta maschio DIN 6499 - Maschiatori - Apparecchi per maschiare e filettare.

Tap and die holders are used on production machines like single-spindle lathes, multi-spindle lathes, NC machines, cnc milling machines, drills and transfer machines. They are used for all the operations of thread and greatly improve tool life preventing frequent breaks. The part of the equipment on which is mounted the tap/die can slide axially due to inner springs and also has a slight radial play respect to the part that is mounted in the machine tool. The axial floating given by the internal springs is very important in the processing phase in which the sense of rotation of the tap/die is inverted. Moreover the axial and radial free moving allows tap to follow the existing drilled hole for high quality work.

## Description and Specifications

Tap and die holders are produced with certified top quality steel, they are hardened and completely grinded. All production cycle is carried out in our factory in Italy with high precision machines and is carefully controlled. Thanks to the availability of stock, we can usually ship the material the same day as order is received.

## Further Information

They can be supplied with metric and inch cylindrical shaft fitting and Vdi fitting.

## Products

Tap die out holders - Tap out holders with compression  
- Die out holders - Double tap out holders - ER tap out holders DIN 6499 - Tapping heads - Tapping heads with VDI DIN 69880 fitting - Tapping chucks.



**PORTA MASCHI AD ESTRAZIONE CON PINZA ERC Tipo 192**

FLOATING TAP HOLDERS WITH EXTENSION - WITH ERC COLLET



**Pinze DIN 6499/B**  
Collets DIN 6499/B

Art. / Code	d	L	H	D	Pinza / Collet	Art. pinza / Collet code	Art. ghiera / Nut code	E
192.715	15.875	32	36	29	ERC 11	050.011	052.211	8
192.716	16	32	36	29	ERC 11	050.011	052.211	8
192.719	19.05	32	36	29	ERC 11	050.011	052.211	8
192.720	20	32	36	29		050.011	052.211	8

192.015	15.875	32	48	29	ERC 16	050.016	052.216	8
192.016	16	32	48	29	ERC 16	050.016	052.216	8
192.019	19.05	32	48	29	ERC 16	050.016	052.216	8
192.020	20	32	48	29	ERC 16	050.016	052.216	8

192.219	19.05	46	56	44	ERC 20	050.020	052.220	12
192.220	20	46	56	44	ERC 20	050.020	052.220	12
192.222	22	46	56	44	ERC 20	050.020	052.220	12
192.225	25	46	56	44	ERC 20	050.020	052.220	12
192.226	25.40	46	56	44	ERC 20	050.020	052.220	12

192.419	19.05	46	70	44	ERC 25	050.025	052.325	12
192.420	20	46	70	44	ERC 25	050.025	052.325	12
192.422	22	46	70	44	ERC 25	050.025	052.325	12

192.325	25	50	64	58	ERC 25	050.025	052.325	16
192.325L	25	80	64	58	ERC 25	050.025	052.325	16
192.326	25.40	50	64	58	ERC 25	050.025	052.325	16
192.326L	25.40	80	64	58	ERC 25	050.025	052.325	16
192.330	30	50	64	58	ERC 25	050.025	052.325	16
192.331	31.75	50	64	58	ERC 25	050.025	052.325	16
192.332	32	50	64	58	ERC 25	050.025	052.325	16
192.332L	32	80	64	58	ERC 25	050.025	052.325	16
192.340	40	85	64	58	ERC 25	050.025	052.325	16

192.525	25	50	66	58	ERC 32	050.032	052.332	16
192.525L	25	80	66	58	ERC 32	050.032	052.332	16
192.526	25.40	50	66	58	ERC 32	050.032	052.332	16
192.526L	25.40	80	66	58	ERC 32	050.032	052.332	16
192.530	30	50	66	58	ERC 32	050.032	052.332	16
192.531	31.75	50	66	58	ERC 32	050.032	052.332	16
192.532	32	50	66	58	ERC 32	050.032	052.332	16
192.532L	32	80	66	58	ERC 32	050.032	052.332	16
192.540	40	85	66	58	ERC 32	050.032	052.332	16

192.625	25	50	84	63	ERC 40	050.040	052.340	16
192.625L	25	80	84	63	ERC 40	050.040	052.340	16
192.626	25.40	50	84	63	ERC 40	050.040	052.340	16
192.626L	25.40	80	84	63	ERC 40	050.040	052.340	16
192.630	30	50	84	63	ERC 40	050.040	052.340	16
192.631	31.75	50	84	63	ERC 40	050.040	052.340	16
192.632	32	50	84	63	ERC 40	050.040	052.340	16
192.632L	32	80	84	63	ERC 40	050.040	052.340	16
192.640	40	85	84	63	ERC 40	050.040	052.340	16

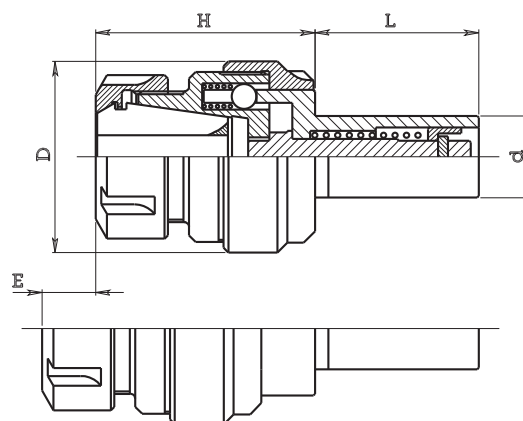

**E = Corsa di estrazione / Extension stroke**  
**H = Quota con pinza inserita / Measure with collet**

**PORTA MASCHI AD ESTRAZIONE E COMPRESIONE**
**FLOATING TAP HOLDERS WITH EXTENSION AND COMPRESSION - WITH ERC COLLET**

**Pinze DIN 6499/B**  
 Collets DIN 6499/B

Art. / Code	d	L	H	D	Pinza / Collet	Art. pinza / Collet code	Art. ghiera / Nut code	E	C
192.715A	15.875	32	36	29	ERC 11	050.011	052.211	5.5	-2.5
192.716A	16	32	36	29	ERC 11	050.011	052.211	5.5	-2.5
192.719A	19.05	32	36	29	ERC 11	050.011	052.211	5.5	-2.5
192.720A	20	32	36	29	ERC 11	050.011	052.211	5.5	-2.5
192.015A	15.875	32	48	29	ERC 16	050.016	052.216	5.5	-2.5
192.016A	16	32	48	29	ERC 16	050.016	052.216	5.5	-2.5
192.019A	19.05	32	48	29	ERC 16	050.016	052.216	5.5	-2.5
192.020A	20	32	48	29	ERC 16	050.016	052.216	5.5	-2.5
192.219A	19.05	46	59	44	ERC 20	050.020	052.220	9	-3
192.220A	20	46	59	44	ERC 20	050.020	052.220	9	-3
192.222A	22	46	59	44	ERC 20	050.020	052.220	9	-3
192.225A	25	46	59	44	ERC 20	050.020	052.220	9	-3
192.226A	25.40	46	59	44	ERC 20	050.020	052.220	9	-3
192.419A	19.05	46	73	44	ERC 25	050.025	052.325	9	-3
192.420A	20	46	73	44	ERC 25	050.025	052.325	9	-3
192.422A	22	46	73	44	ERC 25	050.025	052.325	9	-3
192.325A	25	50	68	58	ERC 25	050.025	052.325	12	-4
192.325AL	25	80	68	58	ERC 25	050.025	052.325	12	-4
192.326A	25.40	50	68	58	ERC 25	050.025	052.325	12	-4
192.326AL	25.40	80	68	58	ERC 25	050.025	052.325	12	-4
192.330A	30	50	68	58	ERC 25	050.025	052.325	12	-4
192.331A	31.75	50	68	58	ERC 25	050.025	052.325	12	-4
192.332A	32	50	68	58	ERC 25	050.025	052.325	12	-4
192.332AL	32	80	68	58	ERC 25	050.025	052.325	12	-4
192.340A	40	85	68	58	ERC 25	050.025	052.325	12	-4
192.525A	25	50	70	58	ERC 32	050.032	052.332	12	-4
192.525AL	25	80	70	58	ERC 32	050.032	052.332	12	-4
192.526A	25.40	50	70	58	ERC 32	050.032	052.332	12	-4
192.526AL	25.40	80	70	58	ERC 32	050.032	052.332	12	-4
192.530A	30	50	70	58	ERC 32	050.032	052.332	12	-4
192.531A	31.75	50	70	58	ERC 32	050.032	052.332	12	-4
192.532A	32	50	70	58	ERC 32	050.032	052.332	12	-4
192.532AL	32	80	70	58	ERC 32	050.032	052.332	12	-4
192.540A	40	85	70	58	ERC 32	050.032	052.332	12	-4
192.625A	25	50	88	63	ERC 40	050.040	052.340	12	-4
192.625AL	25	80	88	63	ERC 40	050.040	052.340	12	-4
192.626A	25.40	50	88	63	ERC 40	050.040	052.340	12	-4
192.626AL	25.40	80	88	63	ERC 40	050.040	052.340	12	-4
192.630A	30	50	88	63	ERC 40	050.040	052.340	12	-4
192.631A	31.75	50	88	63	ERC 40	050.040	052.340	12	-4
192.632A	32	50	88	63	ERC 40	050.040	052.340	12	-4
192.632AL	32	80	88	63	ERC 40	050.040	052.340	12	-4
192.640A	40	85	88	63	ERC 40	050.040	052.340	12	-4

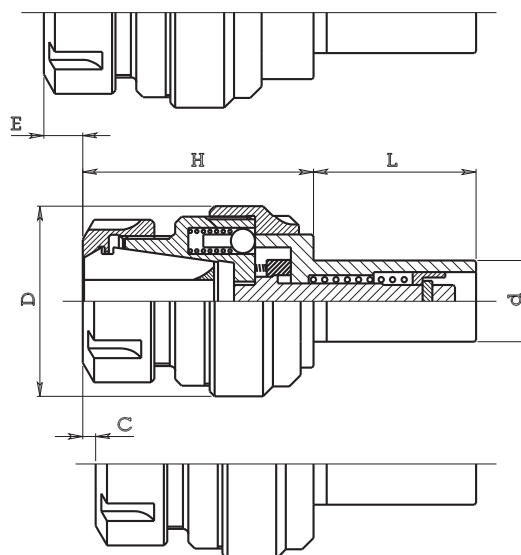

**E = Corsa di estrazione**  
 Extension stroke  
**C = Corsa di compressione**  
 Compression stroke  
**H = Quota con pinza già inserita**  
 Measure with collet

**PORTA MASCHI AD ESTRAZIONE Tipo 190**

FLOATING TAP HOLDERS WITH EXTENSION

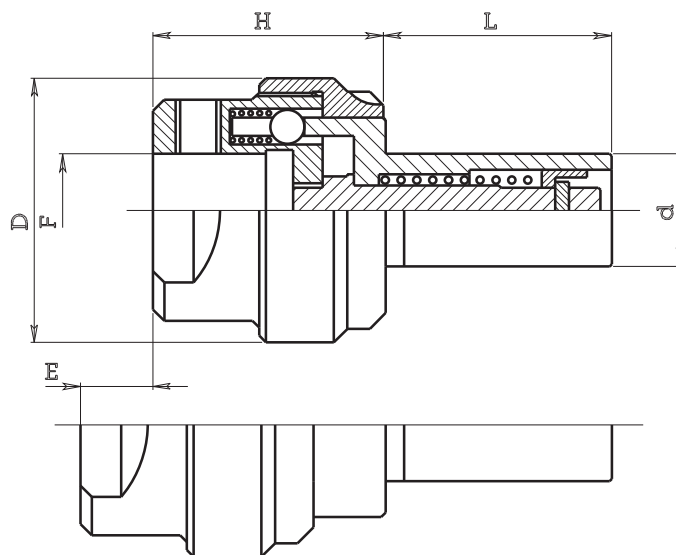

**E = Corsa di estrazione**  
E = Extension stroke

Art. / Code	d	L	H	D	E	F
190.115	15.875	32	29	29	8	10
190.116	16	32	29	29	8	10
190.119	19.05	32	29	29	8	10
190.120	20	32	29	29	8	10
190.219	19.05	46	40	44	12	12
190.219B	19.05	46	40	44	12	11
190.220	20	46	40	44	12	12
190.222	22	46	40	44	12	12
190.225	25	46	40	44	12	12
190.226	25.40	46	40	44	12	12
190.325	25	50	52	58	16	18
190.325L	25	80	52	58	16	18
190.326	25.40	50	52	58	16	18
190.326L	25.40	80	52	58	16	18
190.330	30	50	52	58	16	18
190.331	31.75	50	52	58	16	18
190.332	32	50	52	58	16	18
190.332L	32	80	52	58	16	18
190.340	40	85	52	58	16	18

Art. / Code	d	L	H	D	E	F
190.425	25	50	52	58	16	21
190.426	25.40	50	52	58	16	21
190.430	30	50	52	58	16	21
190.431	31.75	50	52	58	16	21
190.432	32	50	52	58	16	21
190.432L	32	80	52	58	16	21
190.440	40	85	52	58	16	21
190.525	25	50	52	58	16	25
190.525L	25	80	52	58	16	25
190.526	25.40	50	52	58	16	25
190.526L	25.40	80	52	58	16	25
190.530	30	50	52	58	16	25
190.531	31.75	50	52	58	16	25
190.532	32	50	52	58	16	25
190.532L	32	80	52	58	16	25
190.540	40	85	52	58	16	25

**PORTA MASCHI AD ESTRAZIONE E COMPRESIONE Tipo 190 A**
**FLOATING TAP HOLDERS WITH EXTENSION AND COMPRESSION**

Art. / Code	d	L	H	D	E	C	F
190.115A	15.875	32	29	29	5.5	-2.5	10
190.116A	16	32	29	29	5.5	-2.5	10
190.119A	19.05	32	29	29	5.5	-2.5	10
190.120A	20	32	29	29	5.5	-2.5	10

190.219A	19.05	46	43	44	9	-3	12
190.220A	20	46	43	44	9	-3	12
190.222A	22	46	43	44	9	-3	12
190.225A	25	46	43	44	9	-3	12
190.226A	25.40	46	43	44	9	-3	12

190.325A	25	50	56	58	12	-4	18
190.325AL	25	80	56	58	12	-4	18
190.326A	25.40	50	56	58	12	-4	18
190.326AL	25.40	80	56	58	12	-4	18
190.330A	30	50	56	58	12	-4	18
190.331A	31.75	50	56	58	12	-4	18
190.332A	32	50	56	58	12	-4	18
190.332AL	32	80	56	58	12	-4	18
190.340A	40	85	56	58	12	-4	18

190.425A	25	50	56	58	12	-4	21
190.426A	25.40	50	56	58	12	-4	21
190.430A	30	50	56	58	12	-4	21
190.431A	31.75	50	56	58	12	-4	21
190.432A	32	50	56	58	12	-4	21
190.432AL	32	80	56	58	12	-4	21
190.440A	40	85	56	58	12	-4	21

190.525A	25	50	56	58	12	-4	25
190.525AL	25	80	56	58	12	-4	25
190.526A	25.40	50	56	58	12	-4	25
190.526AL	25.40	80	56	58	12	-4	25
190.530A	30	50	56	58	12	-4	25
190.531A	31.75	50	56	58	12	-4	25
190.532A	32	50	56	58	12	-4	25
190.532AL	32	80	56	58	12	-4	25
190.540A	40	85	56	58	12	-4	25

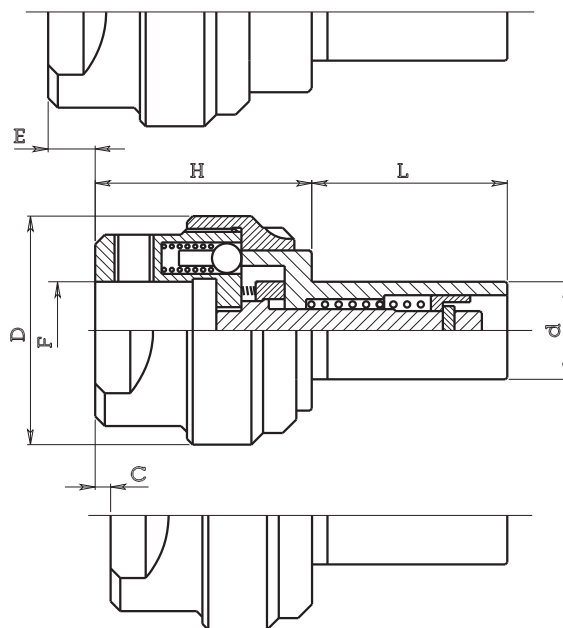

**E = Corsa di estrazione** (Extension stroke)  
**C = Corsa di compressione** (Compression stroke)

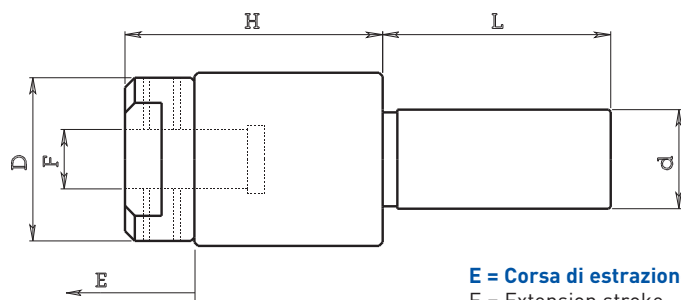
**PORTA MASCHI AD ESTRAZIONE CON CORSA MAGGIORATA Tipo 191**
**FLOATING TAP HOLDERS WITH EXTENSION AND COMPRESSION**

**E = Corsa di estrazione**  
 E = Extension stroke



Art. / Code	d	H	L	D	F	E
191.216	16	48	46	35	12	22
191.219	19.05	48	46	35	12	22
191.220	20	48	46	35	12	22
191.222	22	48	46	35	12	22

Art. / Code	d	H	L	D	F	E
191.216L	16	56	46	35	12	30
191.326	25.40	60	80	45	18	30

**PORTA MASCHI AD ESTRAZIONE CON PINZA ERC Tipo 194**

FLOATING TAP HOLDERS WITH EXTENSION - WITH ERC COLLET



Art. / Code	d	L	H	D	Art. pinza / Collet code	E
194.715 040	15.875	40	21	16	050.011	10
194.716 040	16	40	21	16	050.011	10
194.719 040	19.05	40	21	16	050.011	10
194.720 040	20	40	21	16	050.011	10
194.722 040	22	40	21	16	050.011	10
194.725 040	25	40	21	16	050.011	10
194.726 040	25.40	40	21	16	050.011	10

ERC 11

194.015 040	15.875	40	36	22	050.016	10
194.016 040	16	40	36	22	050.016	10

ERC 16

Pinze DIN 6499/B  
Collets DIN 6499/B

194.019 050	19.05	50	30	22	050.016	14
194.019 070	19.05	70	30	22	050.016	14
194.019 120	19.05	120	30	22	050.016	14
194.020 050	20	50	30	22	050.016	14
194.020 070	20	70	30	22	050.016	14
194.020 120	20	120	30	22	050.016	14
194.022 050	22	50	30	22	050.016	14
194.022 080	22	80	30	22	050.016	14
194.022 120	22	120	30	22	050.016	14
194.025 050	25	50	30	22	050.016	14
194.025 070	25	70	30	22	050.016	14
194.025 120	25	120	30	22	050.016	14
194.026 050	25.40	50	30	22	050.016	14
194.026 070	25.40	70	30	22	050.016	14
194.026 120	25.40	120	30	22	050.016	14

ERC 16

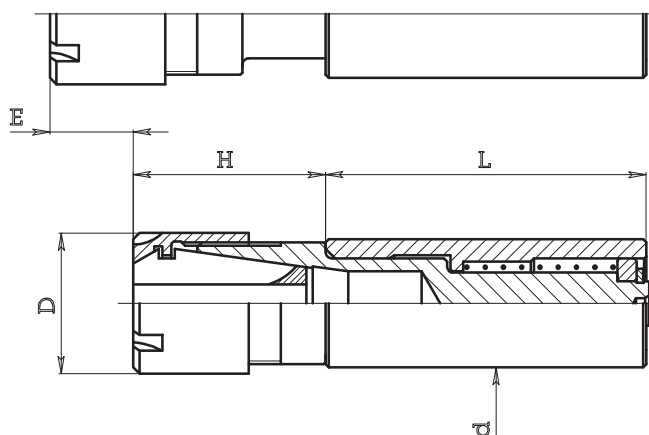

194.119 050	19.05	50	40	28	050.020	14
194.119 070	19.05	70	40	28	050.020	14
194.119 120	19.05	120	40	28	050.020	14
194.120 050	20	50	40	28	050.020	14
194.120 070	20	70	40	28	050.020	14
194.120 120	20	120	40	28	050.020	14
194.122 050	22	50	40	28	050.020	14
194.122 080	22	80	40	28	050.020	14
194.122 120	22	120	40	28	050.020	14
194.125 050	25	50	40	28	050.020	14
194.125 070	25	70	40	28	050.020	14
194.125 120	25	120	40	28	050.020	14
194.126 050	25.40	50	40	28	050.020	14
194.126 070	25.40	70	40	28	050.020	14
194.126 120	25.40	120	40	28	050.020	14

ERC 20

194.219 050	19.05	50	42	35	050.025	14
194.219 070	19.05	70	42	35	050.025	14
194.219 120	19.05	120	42	35	050.025	14
194.220 050	20	50	42	35	050.025	14
194.220 070	20	70	42	35	050.025	14
194.220 120	20	120	42	35	050.025	14
194.222 050	22	50	42	35	050.025	14
194.222 080	22	80	42	35	050.025	14
194.222 120	22	120	42	35	050.025	14
194.225 050	25	50	42	35	050.025	14
194.225 070	25	70	42	35	050.025	14
194.225 120	25	120	42	35	050.025	14
194.226 050	25.40	50	42	35	050.025	14
194.226 070	25.40	70	42	35	050.025	14
194.226 120	25.40	120	42	35	050.025	14

ERC 25

**PORTA MASCHIO DOPPIO AD ESTRAZIONE - GHIERA MINI**
**DOUBLE - SEATED FLOATING TAP HOLDER WITH EXTENSION**

 Pinze DIN 6499/B  
 Collets DIN 6499/B

Art. / Code	d	L	H	D	X	Pinza / Collet	E
195.719 050	19.05	50	16.5	16	0.5 - 7	ERC 11	8
195.719 060	19.05	60	16.5	16	0.5 - 7	ERC 11	8
195.720 050	20	50	16.5	16	0.5 - 7	ERC 11	8
195.720 060	20	60	16.5	16	0.5 - 7	ERC 11	8
195.722 050	22	50	16.5	16	0.5 - 7	ERC 11	8
195.722 060	22	60	16.5	16	0.5 - 7	ERC 11	8
195.022 050	22	50	26	22	0.5 - 10	ERC 16	8
195.022 060	22	60	26	22	0.5 - 10	ERC 16	8
195.022 095	22	95	26	22	0.5 - 10	ERC 16	8
195.025 050	25	50	26	22	0.5 - 10	ERC 16	8
195.025 060	25	60	26	22	0.5 - 10	ERC 16	8
195.026 050	25.40	50	26	22	0.5 - 10	ERC 16	8
195.026 060	25.40	60	26	22	0.5 - 10	ERC 16	8

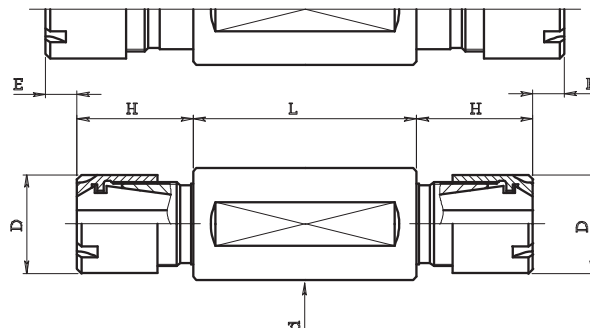
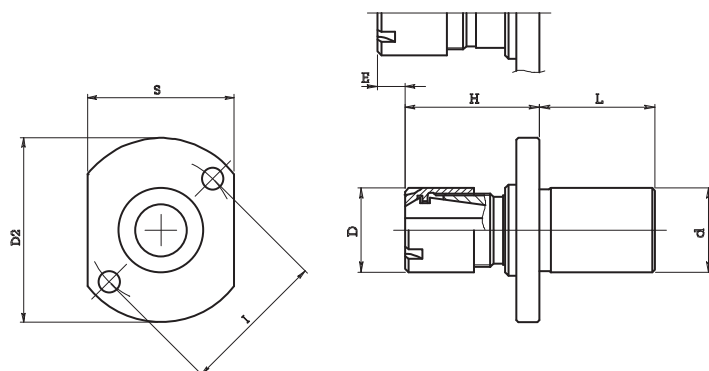

**MANDRINO PORTA MASCHIO AD ESTRAZIONE**
**TAP HOLDER SPINDLE WITH MINI CLAMPING NUT**

 Pinze DIN 6499/B  
 Collets DIN 6499/B

	Art. / Code	d	L	H	D	X	D2	S	I	Pinza / Collet	Art. pinza / Collet code	E
STAR SR 20	196.022 030	22	30	36	22	0.5 - 10	48	38	38	ERC 16	050.016	8
STAR SR 32	196.022 030B	22	30	36	22	0.5 - 10	60	38	50	ERC 16	050.016	8

**PORTA FILIERA PER TORNI A FANTINA MOBILE**
**DIE HOLDER FOR AUTOMATIC SLIDING HEADSTOCK LATHES**

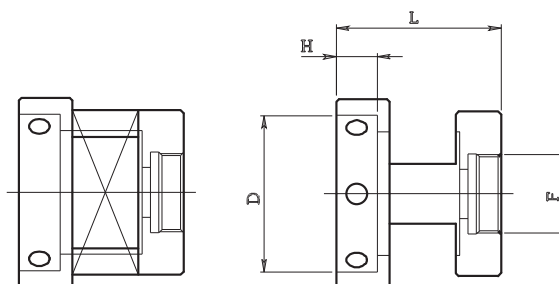
 Da montare al posto della ghiera mini su tutti i mandrini ER11 con filetto 19x1. Articoli: 161.000 - 194.000 - 195.000  
 To be mounted in place of the mini nut on all ER11 spindles with thread 19x1. Code: 161.000 - 194.000 - 195.000

Art. / Code	D	H	L	F / Tread
382.716 025	16	5	25	19x1
382.716 040	16	5	40	19x1
382.720 025B	20	5	25	19x1
382.720.040B	20	5	40	19x1
382.720 025	20	7	25	19x1
382.720 040	20	7	40	19x1
382.725 025	25	9	25	19x1
382.725 040	25	9	40	19x1
382.730 040	30	11	40	19x1
382.738 040	38	10	40	19x1





**PORTA MASCHI A CAMBIO RAPIDO**

QUICK CHANGE FLOATING TAP HOLDERS

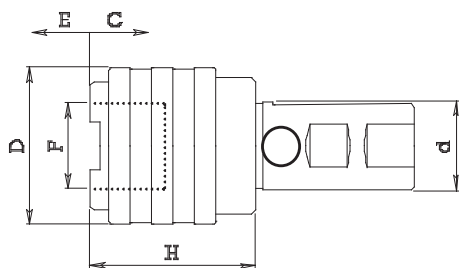

Art. / Code	d	H	D	Estrazione E / Extension E	Compressione C / Compression E	F	Per maschi / Tap capacity
198.120	20	41	38	9	9	19	M3 - M12
198.125	25	41	38	9	9	19	M3 - M12
198.132	32	41	38	9	9	19	M3 - M12
198.140	40	41	38	9	9	19	M3 - M12
198.225	25	63	55	15	15	31	M3 - M20
198.232	32	63	55	15	15	31	M3 - M20
198.240	40	63	55	15	15	31	M3 - M20

**INSERZIONI PORTA MASCHIO A CAMBIO RAPIDO**

ADAPTORS FOR TAP HOLDERS

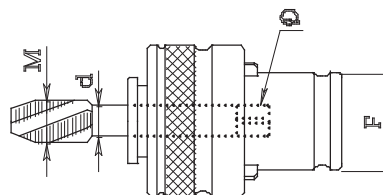
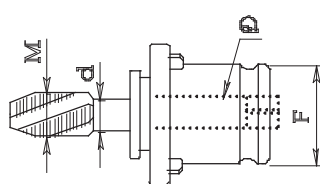

Senza frizione - Without safety clutch

Con frizione registrabile - With safety clutch

Art. / Code	d	Quadro Q / Square Q	M	Fig.	F
Z B0.025	2.5	2.1	M1	1	13
Z B0.028	2.8	2.1	M2-2.5	1	13
Z B0.035	3.5	2.7	M3	1	13
Z B0.045	4.5	3.4	M4	1	13
Z B0.060	6	4.9	M5-6-8	1	13
Z B0.070	7	5.5	M10	1	13
Z B0.080	8	6.2	M8	1	13

Art. / Code	d	Quadro Q / Square Q	M	Fig.	F
Z BF0.025	2.5	2.1	M1	2	13
Z BF0.028	2.8	2.1	M2-2.5	2	13
Z BF0.035	3.5	2.7	M3	2	13
Z BF0.045	4.5	3.4	M4	2	13
Z BF0.060	6	4.9	M5-6-8	2	13
Z BF0.070	7	5.5	M10	2	13
Z BF0.080	8	6.2	M8	2	13

Z B1.035	3.5	2.7	M3	1	19
Z B1.045	4.5	3.4	M4	1	19
Z B1.060	6	4.9	M5-6-8	1	19
Z B1.070	7	5.5	M10	1	19
Z B1.080	8	6.2	M8	1	19
Z B1.090	9	7	M12	1	19
Z B1.100	10	8	M10	1	19
Z B1.110	11	9	M14	1	19

Z BF1.035	3.5	2.7	M3	2	19
Z BF1.045	4.5	3.4	M4	2	19
Z BF1.060	6	4.9	M5-6-8	2	19
Z BF1.070	7	5.5	M10	2	19
Z BF1.080	8	6.2	M8	2	19
Z BF1.090	9	7	M12	2	19
Z BF1.100	10	8	M10	2	19
Z BF1.110	11	9	M14	2	19

Z B2.060	6	4.9	M5-6-8	1	31
Z B2.070	7	5.5	M10	1	31
Z B2.080	8	6.2	M8	1	31
Z B2.090	9	7	M12	1	31
Z B2.100	10	8	M10	1	31
Z B2.110	11	9	M14	1	31
Z B2.120	12	9	M16	1	31
Z B2.140	14	11	M18	1	31
Z B2.160	16	12	M20	1	31
Z B2.180	18	14.5	M22-24	1	31

Z BF2.060	6	4.9	M5-6-8	2	31
Z BF2.070	7	5.5	M10	2	31
Z BF2.080	8	6.2	M8	2	31
Z BF2.090	9	7	M12	2	31
Z BF2.100	10	8	M10	2	31
Z BF2.110	11	9	M14	2	31
Z BF2.120	12	9	M16	2	31
Z BF2.140	14	11	M18	2	31
Z BF2.160	16	12	M20	2	31
Z BF2.180	18	14.5	M22-24	2	31

**PORTA FILIERA AD ESTRAZIONE Tipo 210**
**FLOATING DIE HOLDER WITH EXTENSION**

Art. / Code	d	L	H	D	A	Art. cappello / Die holder bush code	E	K	Y
210.115	15.875	32	33	36	21	218....	8	10	20
210.116	16	32	33	36	21	218....	8	10	20
210.119	19.05	32	33	36	21	218....	8	10	20
210.120	20	32	33	36	21	218....	8	10	20

210.219	19.05	46	42	57	32	220....	12	13	23
210.220	20	46	42	57	32	220....	12	13	23
210.222	22	46	42	57	32	220....	12	13	23
210.225	25	46	42	57	32	220....	12	13	23
210.226	25.40	46	42	57	32	220....	12	13	23

210.325	25	50	51	70	45	230....	16	22	31
210.325L	25	80	51	70	45	230....	16	22	31
210.326	25.40	50	51	70	45	230....	16	22	31
210.326L	25.40	80	51	70	45	230....	16	22	31
210.330	30	50	51	70	45	230....	16	22	31
210.331	31.75	50	51	70	45	230....	16	22	31
210.332	32	50	51	70	45	230....	16	22	31
210.332L	32	80	51	70	45	230....	16	22	31
210.340	40	85	51	70	45	230....	16	22	31

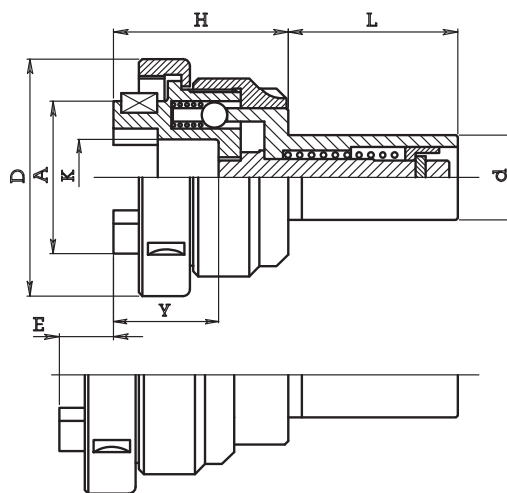

**E = Corsa di estrazione**  
 E = Extension stroke

**PORTA FILIERA AD ESTRAZIONE E COMPRESIONE Tipo 210 A**
**FLOATING DIE HOLDER WITH EXTENSION AND COMPRESSION**

Art. / Code	d	L	H	D	A	Art. cappello / Die holder bush code	E	C	K	Y
210.115A	15.875	32	33	36	21	218....	5.5	-2.5	10	20
210.116A	16	32	33	36	21	218....	5.5	-2.5	10	20
210.119A	19.05	32	33	36	21	218....	5.5	-2.5	10	20
210.120A	20	32	33	36	21	218....	5.5	-2.5	10	20

210.219A	19.05	46	45	57	32	220....	9	-3	13	23
210.220A	20	46	45	57	32	220....	9	-3	13	23
210.222A	22	46	45	57	32	220....	9	-3	13	23
210.225A	25	46	45	57	32	220....	9	-3	13	23
210.226A	25.40	46	45	57	32	220....	9	-3	13	23

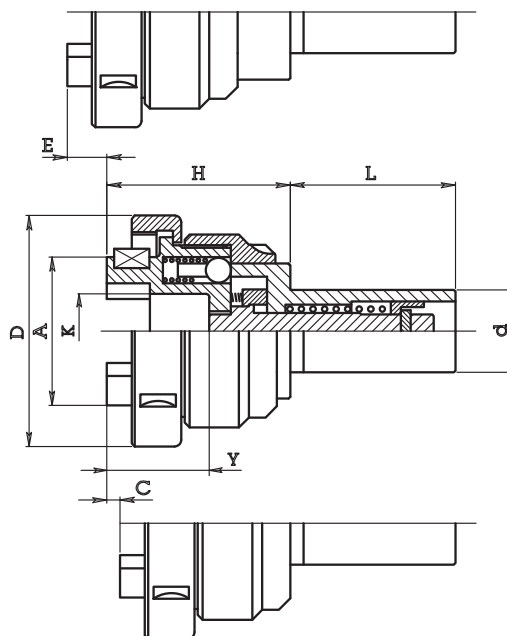
210.325A	25	50	55	71	45	230....	12	-4	22	31
210.325AL	25	80	55	71	45	230....	12	-4	22	31
210.326A	25.40	50	55	71	45	230....	12	-4	22	31
210.326AL	25.40	80	55	71	45	230....	12	-4	22	31
210.330A	30	50	55	71	45	230....	12	-4	22	31
210.331A	31.75	50	55	71	45	230....	12	-4	22	31
210.332A	32	50	55	71	45	230....	12	-4	22	31
210.332AL	32	80	55	71	45	230....	12	-4	22	31
210.340A	40	85	55	71	45	230....	12	-4	22	31

**E = Corsa di estrazione**  
 Extension stroke  
**C = Corsa di compressione**  
 Compression stroke

**PORTA FILIERA CON ESTRAZIONE MAGGIORATA Tipo 211**  
FLOATING DIE HOLDER (BIGGER EXTENSION)

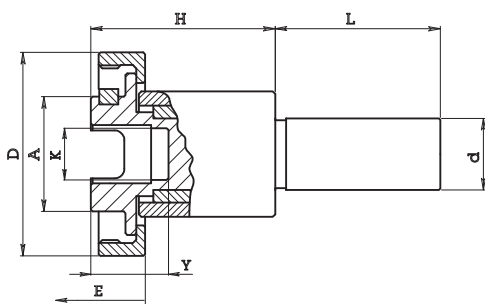

Art. / Code	d	H	L	D	A	Art. cappello / Die holder bush code	E	K	Y
211.216	16	51	46	57	32	220....	22	10	28
211.219	19.05	51	46	57	32	220....	22	10	28
211.220	20	51	46	57	32	220....	22	10	28
211.222	22	51	46	57	32	220....	22	10	28
211.216L	16	59	46	57	32	220....	30	10	47
211.326	25.40	65	80	71	45	230....	30	22	40

**E = Corsa di estrazione**  
E = Extension stroke

**CAPPELLOTTI PORTA FILIERA Tipo 218 Tipo 220 Tipo 230**  
DIE HOLDER CAPS

Art. / Code	D	S	I	A	G
218.116	16	5	2	21	28x1
218.120	20	5	2	21	28x1
218.120B	20	7	2	21	28x1
218.125	25	9	2	21	28x1
218.130	30	11	3	21	28x1
220.116	16	5	5	32	SG 48x1.5
220.120	20	5	5	32	SG 48x1.5
220.220	20	7	3	32	SG 48x1.5
220.125	25	9	3	32	SG 48x1.5
220.130	30	11	3	32	SG 48x1.5
220.138	38	10	6	32	SG 48x1.5
220.238	38	14	3	32	SG 48x1.5
220.145	45	14	3	32	SG 48x1.5
220.245	45	18	3	32	SG 48x1.5
220.150	50	16	4	32	SG 48x1.5
220.155	55	16	4	32	SG 48x1.5
230.220	20	7	9	45	SG 60x1.5
230.125	25	9	7	45	SG 60x1.5
230.130	30	11	5	45	SG 60x1.5
230.138	38	10	6	45	SG 60x1.5
230.238	38	14	3	45	SG 60x1.5
230.145	45	14	3	45	SG 60x1.5
230.245	45	18	4	45	SG 60x1.5
230.150	50	16	6	45	SG 60x1.5
230.155	55	16	6	45	SG 60x1.5
230.165	65	18	6	45	SG 60x1.5
230.175	75	20	6	45	SG 60x1.5

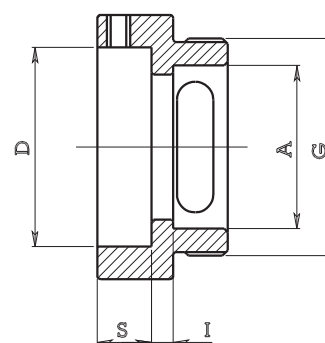

**PORTA MASCHI A SGANCIAMENTO Tipo 180**  
**RELEASING TAP HOLDERS**

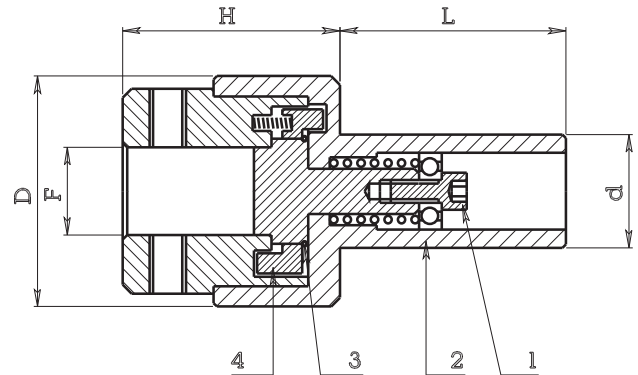

Art. / Code	d	L	H	D	F	C
180.219	19.05	50	44	51	18	4
180.220	20	50	44	51	18	4
180.222	22	50	44	51	18	4
180.225	25	50	44	51	18	4
180.226	25.40	50	44	51	18	4
180.230	30	50	44	51	18	4
180.231	31.75	50	44	51	18	4
180.232	32	50	44	51	18	4
180.322	22	50	54	51	25	4
180.325	25	50	54	51	25	4
180.326	25.40	50	54	51	25	4
180.330	30	50	54	51	25	4
180.331	31.75	50	54	51	25	4
180.332	32	50	54	51	25	4



**C = Corsa di compensazione assiale (solo a trazione) prima di arrivare al punto di sganciamento**  
 C = Length compensation's stroke (only expansion) before to arrive at releasing's point

**PORTA FILIERA A SGANCIAMENTO Tipo 200**  
**RELEASING DIE HOLDERS**

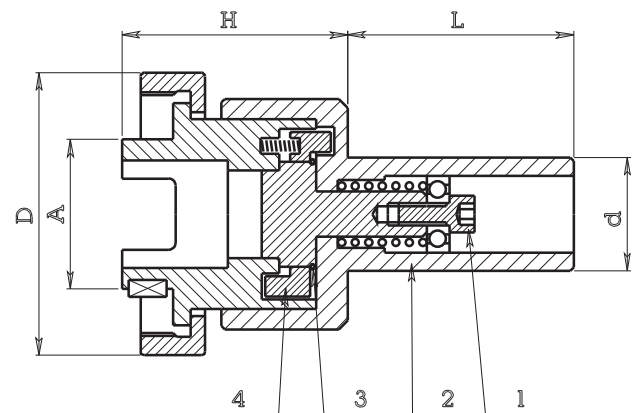
Art. / Code	d	L	H	D	F	C	Art. cappello / Die holder bush code
200.219	19.05	50	46	57	32	4	220....
200.220	20	50	46	57	32	4	220....
200.222	22	50	46	57	32	4	220....
200.225	25	50	46	57	32	4	220....
200.226	25.40	50	46	57	32	4	220....
200.230	30	50	46	57	32	4	220....
200.231	31.75	50	46	57	32	4	220....
200.232	32	50	46	57	32	4	220....
200.322	22	50	51	71	45	4	230....
200.325	25	50	51	71	45	4	230....
200.326	25.40	50	51	71	45	4	230....
200.330	30	50	51	71	45	4	230....
200.331	31.75	50	51	71	45	4	230....
200.332	32	50	51	71	45	4	230....



**C = Corsa di compensazione assiale (solo a trazione) prima di arrivare al punto di sganciamento**  
 C = Length compensation's stroke (only expansion) before to arrive at releasing's point

**P. MASCHI e P. FILIERE SONO ADATTI SIA PER FILETTI DESTRI CHE SINISTRI**  
 Per predisporli in senso destro e/o sinistro occorre procedere come segue:

- A - Svitare la vite di 5 MA n. 1 (in questo modo si libera il corpo n. 2)
- B - Togliere la molla n. 3
- C - Capovolgere il settore n. 4
- D - Rimontare il tutto

**NOTA BENE:**

Il porta maschi ed i porta filiere, salvo controindicazioni all'atto dell'ordine, vengono forniti predisposti per filetti destri.

**TAP and DIE HOLDER ARE SUITABLE FOR BOTH RIGHT and LEFT TRHEADS**  
 Proceed as follow to arrange them to the right or left side:

- A - Unscrew the 5 MA schew n.1 (by doing so you release casing n.2)
- B - Remove the spring n.3
- C - Tip-over sector n.4
- D - Re-assemble everything

**ATTENTION:**

The screw holders and the die holders are supplied standard for **right-hand threads**, unless stated otherwise in the original order

**PORTA FILIERA SENZA GHIERA Tipo 380**

DIE HOLDER WITHOUT NUT

Art. / Code	D	S	d	H
380.116	16	5	6	39
380.116B	16	5	8	39
380.120	20	5	6	42
380.120B	20	5	8	42
380.120C	20	7	6	42
380.120D	20	7	8	42
380.125	25	9	8	50
380.125B	25	9	10	50
380.130	30	11	8	56
380.130B	30	11	10	56
380.135	35	12	10	56
380.135B	35	12	8	56
380.138	38	10	12	56
380.138C	38	14	12	56

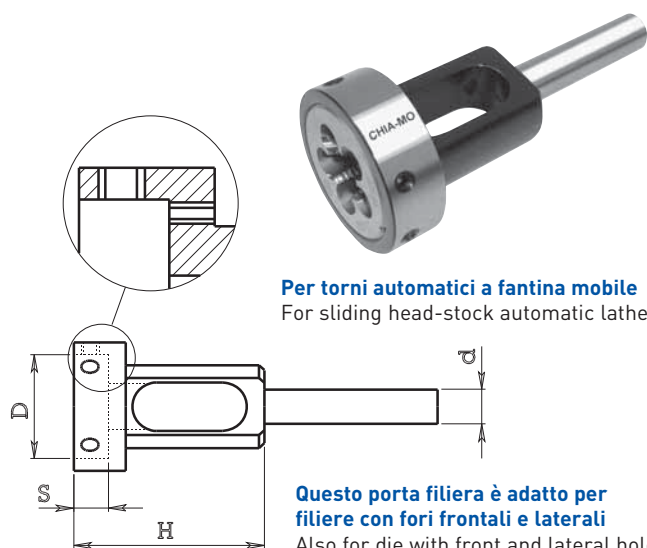

**PORTA FILIERA CON GHIERA Tipo 380**

DIE HOLDER WITH NUT

Art. / Code	D	d	H
380.616	16	6	39
380.616B	16	8	39
380.620	20	6	42
380.620B	20	8	42
380.625	25	8	50
380.625B	25	10	50
380.630	30	8	56
380.630B	30	10	56
380.635	35	10	56

Art. / Code	
380.616 1	ghiera per art. 380.616 (nut for code 380.616)
380.620 1	ghiera per art. 380.620 (nut for code 380.620)
380.625 1	ghiera per art. 380.625 (nut for code 380.625)
380.630 1	ghiera per art. 380.630 (nut for code 380.630)

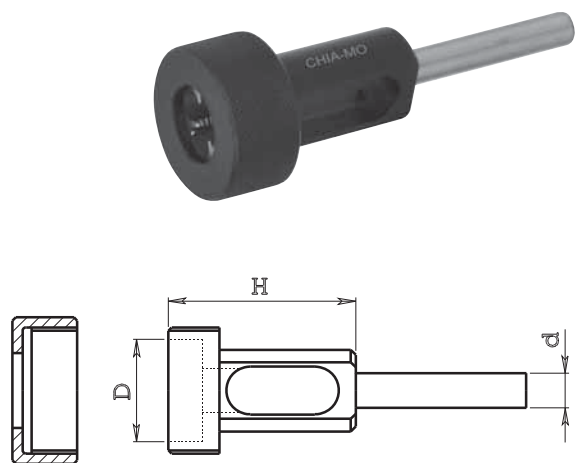

**PORTA FILIERA PER APPARECCHIO FORA FILETTI Tipo 382**

DIE HOLDER FOR DRILL-THREAD DEVICE

TRAUB A 15-20-25

Art. / Code	D	H	L	F
382.112	12	4	32	25x1.5 sx
382.116	16	5	32	25x1.5 sx
382.120	20	7	32	25x1.5 sx
382.125	25	9	32	25x1.5 sx
382.130	30	11	32	25x1.5 sx
382.138	38	14	32	25x1.5 sx

Art. / Code	D	H	L	F
382.212	12	4	46	25x1.5 sx
382.216	16	5	46	25x1.5 sx
382.220	20	7	46	25x1.5 sx
382.225	25	9	46	25x1.5 sx
382.230	30	11	46	25x1.5 sx
382.238	38	14	46	25x1.5 sx

Art. / Code	D	H	L	F
382.312	12	4	62	25x1.5 sx
382.316	16	5	62	25x1.5 sx
382.320	20	7	62	25x1.5 sx
382.325	25	9	62	25x1.5 sx
382.330	30	11	62	25x1.5 sx
382.338	38	14	62	25x1.5 sx

SAIC B26-30 / ITS 26 / GIORGI 20-25-30

Art. / Code	D	H	L	F
382.412	12	4	32	26x1.5 sx
382.416	16	5	32	26x1.5 sx
382.420	20	7	32	26x1.5 sx
382.425	25	9	32	26x1.5 sx
382.430	30	11	32	26x1.5 sx
382.438	38	14	32	26x1.5 sx

Art. / Code	D	H	L	F
382.512	12	4	46	26x1.5 sx
382.516	16	5	46	26x1.5 sx
382.520	20	7	46	26x1.5 sx
382.525	25	9	46	26x1.5 sx
382.530	30	11	46	26x1.5 sx
382.538	38	14	46	26x1.5 sx

Art. / Code	D	H	L	F
382.612	12	4	62	26x1.5 sx
382.616	16	5	62	26x1.5 sx
382.620	20	7	62	26x1.5 sx
382.625	25	9	62	26x1.5 sx
382.630	30	11	62	26x1.5 sx
382.638	38	14	62	26x1.5 sx

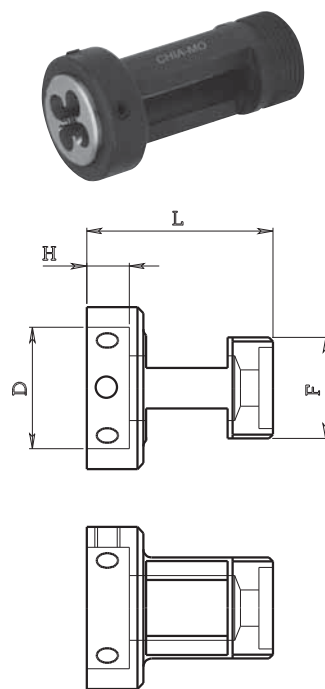

**PORTA FILIERA PER MASCHIATRICI E TRAPANI Tipo 384**
**DIE HOLDERS FOR TAPPING AND DRILLING MACHINES**

Art. / Code	D	H	d	L
384.116	16	5	9	60
384.120	20	7	9	60
384.125	25	9	9	60
384.130	30	11	9	60
384.138	38	10	12	60
384.138B	38	14	12	60
384.145	45	14	15	66
384.145B	45	18	15	66

Art. / Code	D	H	L	Cono morse / M.T.
384.716	16	5	60	C.M.2
384.720	20	7	60	C.M.2
384.725	25	9	60	C.M.2
384.730	30	11	60	C.M.2
384.738	38	10	60	C.M.2
384.738B	38	14	60	C.M.2
384.745	45	14	66	C.M.2
384.745B	45	18	66	C.M.2

**CODULO DI TRASCINAMENTO PER CONO MORSE 2**
**DRIVING SHAFT PIN FOR MT2**

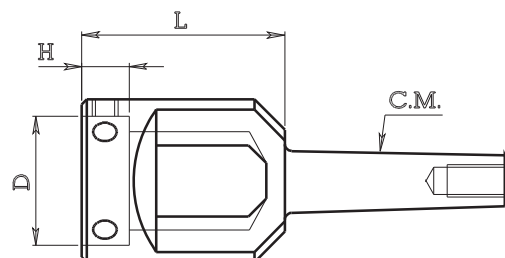
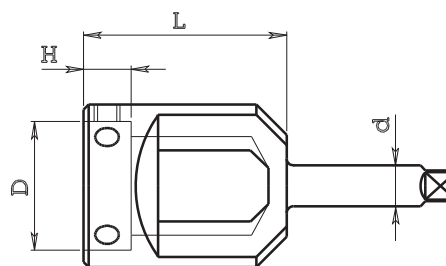
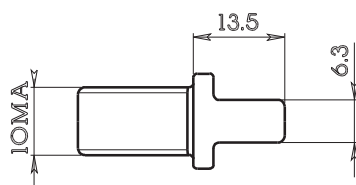
 Art. / Code **164.992**

**PORTA FILIERA PER TORNI PLURIMANDRINO Tipo 380**
**DIE HOLDER FOR MULTISPINDLE LATHES**

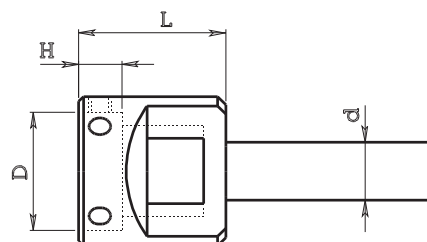
Art. / Code	D	H	d	L
380.525	25	9	20	35
380.530	30	11	20	35
380.538	38	10	20	35
380.538B	38	14	20	40
380.545	45	14	20	40
380.545B	45	18	20	40
380.550	50	16	20	40
380.555B	55	16	20	40

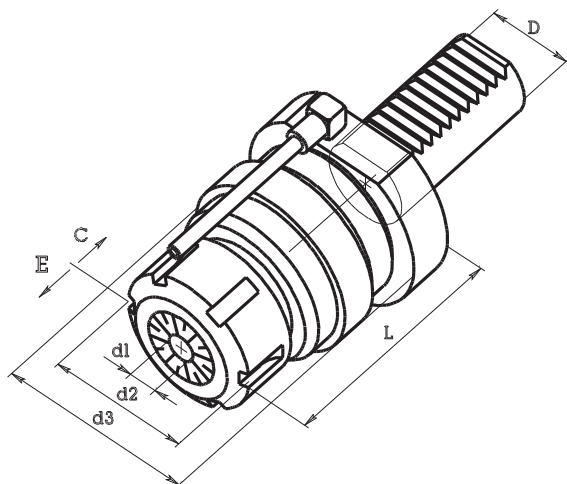

**PORTA MASCHI AD ESTRAZIONE E COMPRESIONE**

EXTRACTION AND COMPRESSION TAP HOLDERS



Art. / Code	D	Pinza / Collet	d1 min	d1 max	d2	d3	L	E	C
9 M1.20.20	20	ERC 20	1	13	34	50	71	9	-3
9 M1.20.25	20	ERC 25	1	16	42	50	100	9	-3
9 M1.30.25	30	ERC 25	1	16	42	68	84	12	-4
9 M1.30.32	30	ERC 32	2	20	50	68	86	12	-4
9 M1.30.40	30	ERC 40	3	30	63	68	104	12	-4
9 M1.40.25	40	ERC 25	1	16	42	83	86	12	-4
9 M1.40.32	40	ERC 32	2	20	50	83	88	12	-4
9 M1.40.40	40	ERC 40	3	30	63	83	106	12	-4

Pinze DIN 6499/B  
 Collets DIN 6499/B

**PORTA FILIERE AD ESTRAZIONE E COMPRESIONE**

EXTRACTION AND COMPRESSION DIE HOLDERS

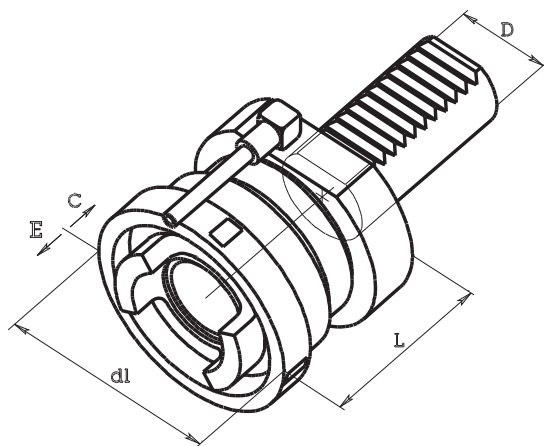

Art. / Code	D	Art. cappello / Die holding cap code	d1	L	E	C
9 Y1.20.20	20	220....	57	57	9	-3
9 Y1.30.30	30	230....	70	71	12	-4
9 Y1.40.30	40	230....	70	73	12	-4

A pag. 165 sono descritti i cappellotti porta filiera disponibili a magazzino.  
 Die holder caps available from warehouse are listed on pag. 165.

# CHIA-MO

WWW.CHIAMO.IT

I T A L Y



**CHIA-MO srl**

Via Caduti di Sabbiano, 12  
40011 Anzola dell'Emilia (Bo) Italy  
Tel. +39 051 734153 - Fax +39 051 734958  
info@chiamo.it - www.chiamo.it

